

DOUBLE LAYER ROOF – ANCHORED SYSTEM, TIMBER SUPPORTING STRUCTURE
BITUMEN SHEET WATERPROOFING

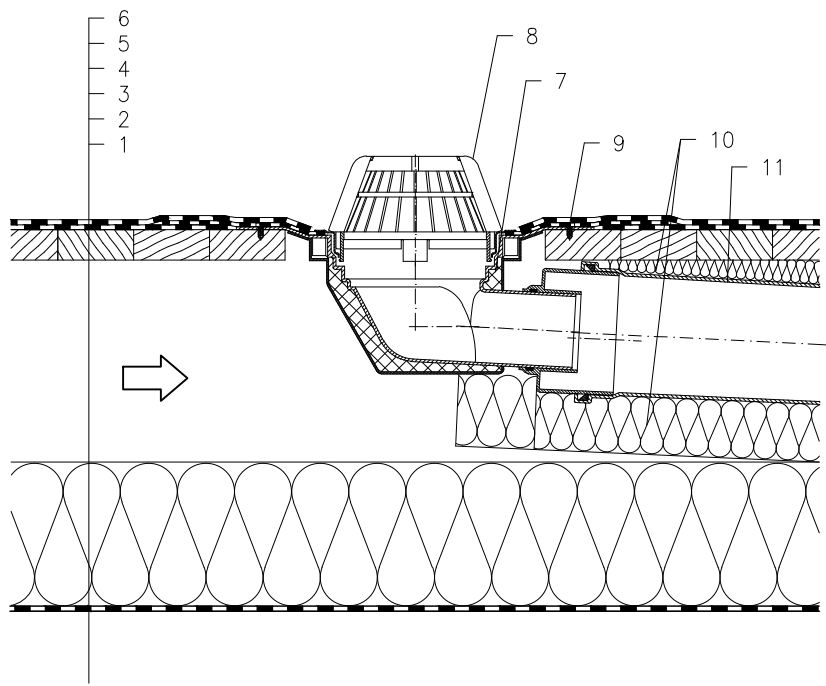

- 1 SUPPORT CONSTRUCTION
- 2 MOISTURE STOP AND TEMPORARY SAFETY WATERPROOFING FROM BITUMEN SHEET OR PLASTIC FOIL
- 3 THERMAL INSULATION
- 4 AIR LAYER
- 5 UPPER CLADDING SUPPORTING STRUCTURE – TIMBER
- 6 BITUMEN SHEET WATERPROOFING MECHANICALLY ANCHORED
- 7 FLAT-ROOF DRAIN HL64H WITH INSULATED DRAIN BODY, WITH FACTORY WELDED BITUMEN MEMBRANE \varnothing 500 mm, THICKNESS 4 mm
- 8 DOMED PLASTIC GRATE \varnothing 180 mm (INCL. WITH HL64H)
- 9 ANCHOR BOLT
- 10 DOWNPIPE THERMAL INSULATION
- 11 DOWNPIPE

NOTE:
 FLAT-ROOF DRAIN HL64.1H HEATED (230V, 10-30 WATTS) CAN BE USED.
 ASSEMBLY INLET: 260 x 380 mm