

ROOF WITH THERMAL INSULATION – INTENSIVE GRASSING, COMBINED ORDER OF LAYERS
PLASTIC FOIL

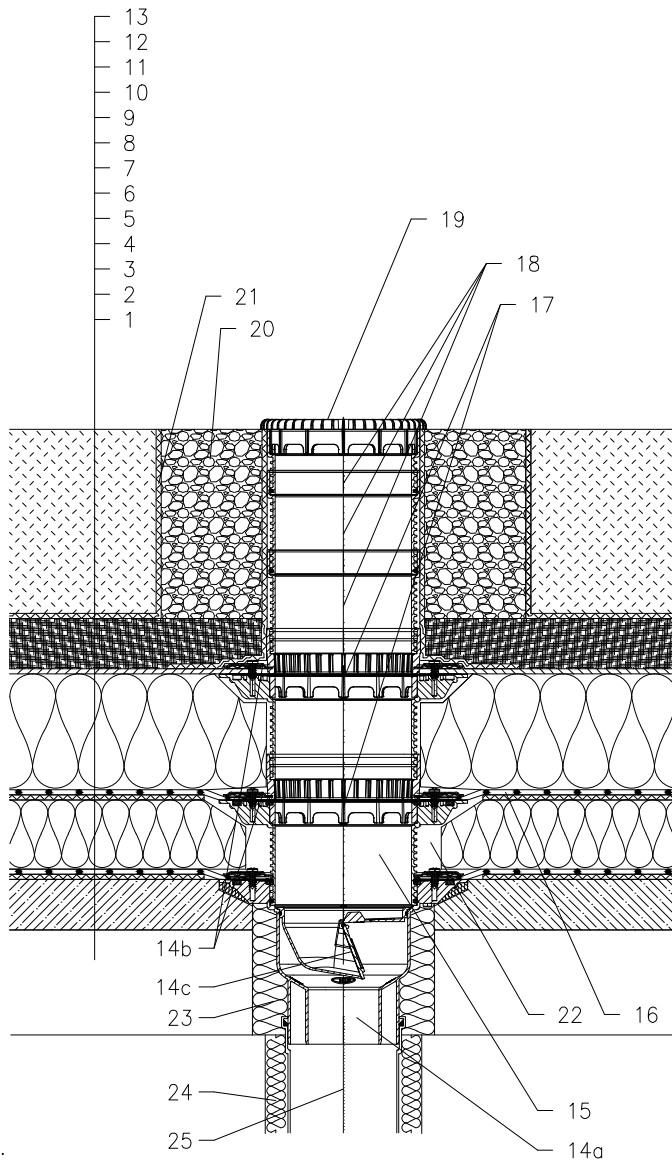

- 1 SUPPORT CONSTRUCTION
- 2 CONCRETE GRAVITY LAYER
- 3 SEPARATING AND DILATATION LAYER
- 4 MOISTURE STOP AND TEMPORARY SAFETY WATERPROOFING
- 5 THERMAL INSULATION
- 6 SEPARATING AND DILATATION LAYER
- 7 PLASTIC FOIL WATERPROOFING
- 8 DRAINAGE LAYER
- 9 XPS THERMAL INSULATION
- 10 DRAINAGE LAYER
- 11 WATER ACCUMULATING LAYER
- 12 FILTER LAYER
- 13 VEGETATION LAYER (OVER 200mm)
- 14a DRAIN BODY HL3100TK WITH FLANGE
- 14b SEALING KIT HL8300.0 – WITHOUT SHEETING,
(ALL-PURPOSE FOR UNRUFFED ROOF SHEETINGS)
(alternative HL8300.P – WHEN USING PVC SHEETINGS)
- 14c FROST-PROOF FLAP HL05100.4E
(NOT INCLUDED IN HL3100TK)
- 15 EXTENSION HL8500 WITH FLANGE
INCL. O-RING, (HL3400)
- 16 PRE-CUT PART FOR SEALING COLLAR, SEE TOPIC "ATTACHEMENTS"
- 17 LEAF STRAINER HL150
- 18 EXTENSION HL3400
- 19 FLAT LEAF STRAINER 151
(NOT INCLUDED IN HL3100TK)
- 20 GRANULAR FILL
- 21 SEPARATING LAYER
- 22 FILL FREE SPACE WITH MINERAL WOOL
- 23 ASSEMBLY FOAM
- 24 DOWNPIPE THERMAL INSULATION
- 25 DOWNPIPE

NOTICE:

TO HEAT THE DRAIN, YOU MAY USE HEATING KIT HKL156 WITH REGULATING HEAT SOURCE 40W/M; 230 V; (APR. 12-14W HEATING TAPE). (THE HEATING TAPE INCL. THERMAL INSULATION MUST BE PULLED ON THE DRAIN BODY BEFORE INSTALLATION)
RECOMMENDED BOREHOLE DIAMETER IS $\phi 220\text{mm}$, $\text{zr} 220 \times 220\text{mm}$.
DURING INSTALLATION TAKE CARE, THAT THE FLANGE POSITION IS ON THE LOWEST LEVEL OF DRAINAGE. WE RECOMMEND, TO SITE IT APPR. 1cm BELOW THE SCREED.
TO AVOID CONDENSATE WATER TAKE CARE OF THERMAL INSULATION ON THE CONSTRUCTION SITE.

142322Z