

WARM ROOF – WALKABLE, REVERSE LAYER ORDER STRUCTURE, PLASTIC FOIL WATERPROOFING
PAVEMENT ON STANDS

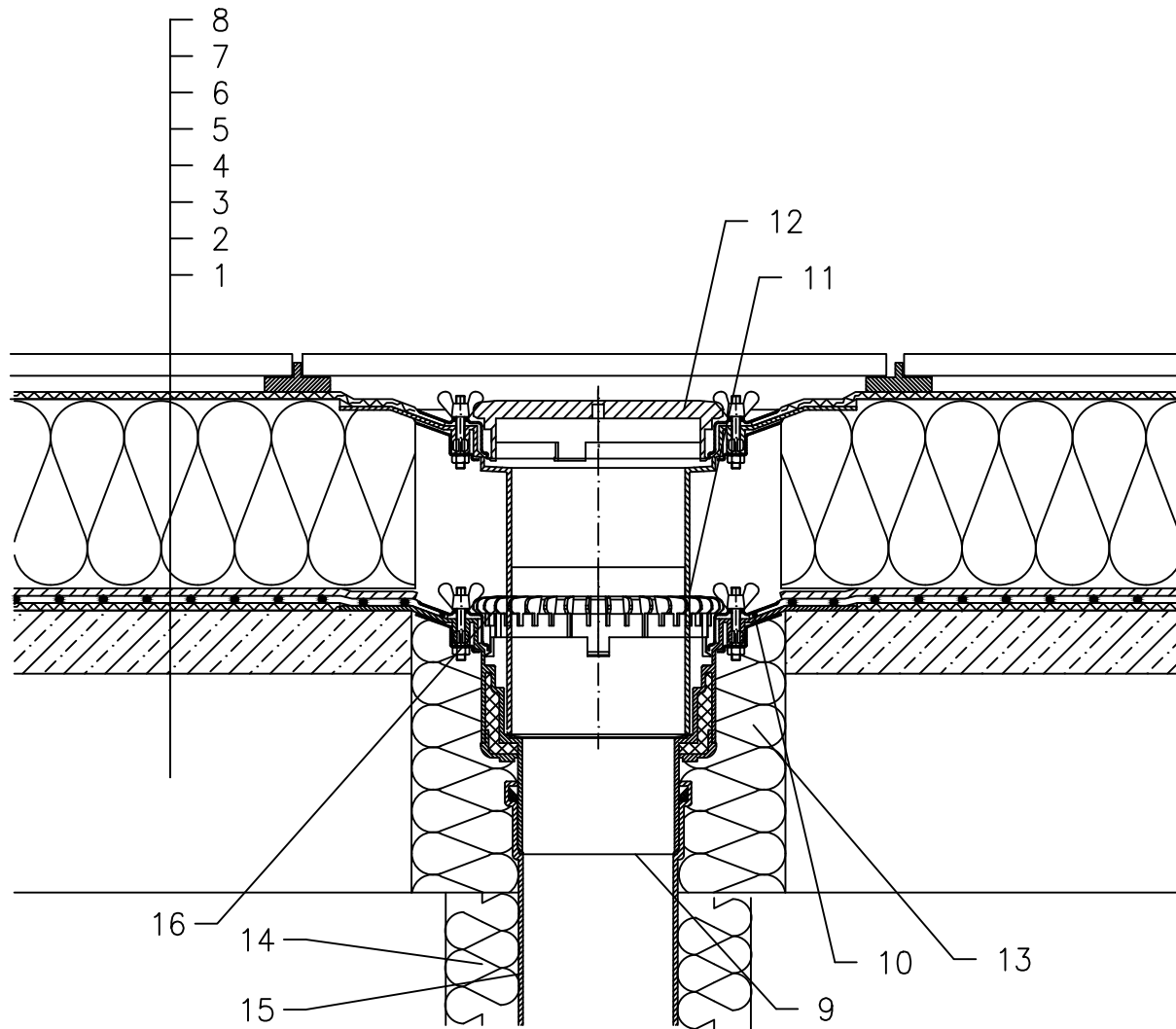

- 1 SUPPORT CONSTRUCTION
- 2 GRAVITY LAYER
- 3 DILATATION LAYER
- 4 PLASTIC FOIL WATERPROOFING LAID LOOSE
- 5 DILATATION AND DRAINAGE LAYER
- 6 THERMAL INSULATION FROM XPS
- 7 DILATATION LAYER
- 8 PAVEMENT ON STANDS
- 9 FLAT-ROOF DRAIN HL62 WITH INSULATED DRAIN BODY, FLANGE AND STAINLESS STEEL CLAMPING RING (FOR PVC SHEETINGS FLAT -ROOF DRAIN HL62P; FOR FPO SHEETINGS BASED ON PP FLAT -ROOF DRAIN HL62F)
- 10 SEALING PACKING (SEE-ACCESSORIES)
- 11 EXTENSION HL65 WITH FLANGE, STAINLESS STEEL CLAMPING RING
- 12 FLAT GRATE HL170 (SUPPLIED INLET)
- 13 ASSEMBLY FOAM
- 14 DOWNPIPE THERMAL INSULATION
- 15 DOWNPIPE
- 16 DRAINAGE ELEMENT HL161

NOTE:

FLAT-ROOF DRAIN HL62.1(FOR PVC SHEETINGS FLAT -ROOF DRAIN HL62.1P;
FOR FPO SHEETINGS BASED ON PP FLAT -ROOF DRAIN HL62.1F)HEATED (230V,
10-30 WATTS) CAN BE USED.

ASSEMBLY INLET: \varnothing 255 mm, OR 255 x 380 mm