

ROOF WITH THERMAL INSULATION – CLASSICAL LAYERS, PLASTIC FOIL
TERRACE, PAVEMENT IN CONCRETE, WITH THINBED WATERPROOFING

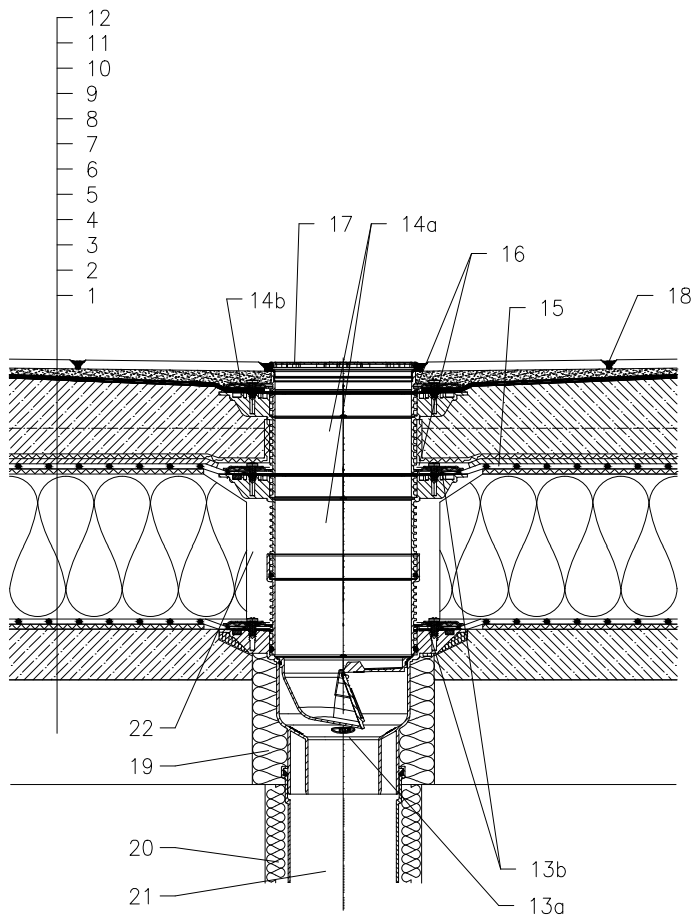

- 1 SUPPORT CONSTRUCTION
- 2 CONCRETE GRAVITY LAYER
- 3 SEPARATING AND DILATATION LAYER
- 4 MOISTURE STOP AND TEMPORARY SAFETY WATERPROOFING
- 5 THERMAL INSULATION
- 6 SEPARATING AND DILATATION LAYER
- 7 PLASTIC FOIL WATERPROOFING
- 8 DRAINAGE LAYER
- 9 FILTER LAYER
- 10 CONCRETE SLAB
- 11 THINBED WATERPROOFING
- 12 PAVEMENT EMBEDDED IN CONCRETE
- 13a TERRACE DRAIN HL3100T WITH FROST-PROOF FLAP AND FLANGE
LOAD CLASSIFICATION K3 (MAX 300 kg)
- 13b SEALING KIT HL8300.0 – WITHOUT SHEETING,
(ALL-PURPOSE FOR UNRUFFED ROOF SHEETINGS)
(ALTERNATIVE HL8300.P – WHEN USING PVC SHEETINGS)
- 14a EXTENSION HL85N WITH FLANGE INCL. O-RING
- 14b SEALING KIT HL83.M – WITH LAMINATED FLEECE
(500x500 mm)
- 15 PRE-CUT PART FOR SEALING COLLAR, SEE TOPIC "ATTACHEMENTS"
- 16 NO TIGHT CONNECTION BECAUSE OF DISCHARGE OF LEAKAGE WATER
- 17 EXTENSION WITH STAINLESS STEEL GRATE 138x138 mm
AND STAINLESS STEEL FRAME 145x145 mm
(INCLUDED IN HL3100T)
- 18 JOINT FILLER
- 19 ASSEMBLY FOAM
- 20 DOWNPIPE THERMAL INSULATION
- 21 DOWNPIPE
- 22 FILL FREE SPACE WITH MINERAL WOOL

NOTICE:

TO HEAT THE DRAIN, YOU MAY USE HEATING KIT HKL156 WITH REGULATING HEAT SOURCE 40W/M; 230 V; (APR. 12-14W HEATING TAPE). (THE HEATING TAPE INCL. THERMAL INSULATION MUST BE PULLED ON THE DRAIN BODY BEFORE INSTALLATION)
RECOMMENDED BOREHOLE DIAMETER IS $\varnothing 220\text{mm}$, $\varnothing 220 \times 220\text{mm}$.
DURING INSTALLATION TAKE CARE, THAT THE FLANGE POSITION IS ON THE LOWEST LEVEL OF DRAINAGE. WE RECOMMEND, TO SITE IT APPR. 1cm BELOW THE SCREED.
TO AVOID CONDENSATE WATER TAKE CARE OF THERMAL INSULATION ON THE CONSTRUCTION SITE.

122113CZ