

ROOF WITH THERMAL INSULATION – CLASSICAL LAYERS, BITUMEN SHEETS
 TERRACE, PAVEMENT IN CONCRETE, WITH THINBED WATERPROOFING

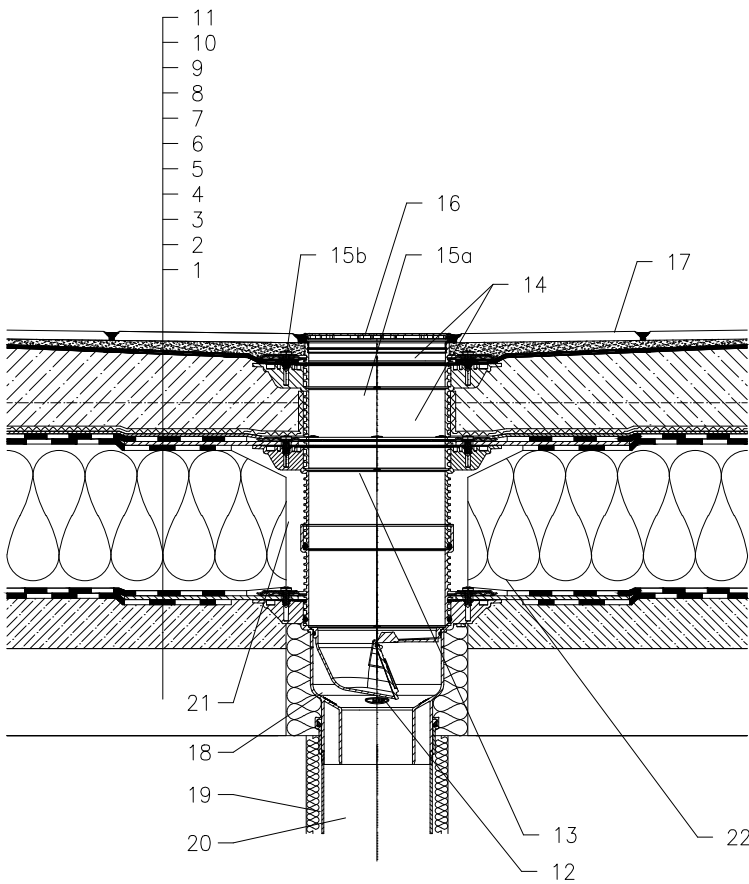

- 1 SUPPORT CONSTRUCTION
- 2 CONCRETE GRAVITY LAYER
- 3 MOISTURE STOP AND TEMPORARY SAFETY WATERPROOFING FROM BITUMEN SHEET
- 4 THERMAL INSULATION
- 5 BITUMEN SHEET WATERPROOFING NON SOLID GLUED OR LAID LOOSE
- 6 BITUMEN SHEET WATERPROOFING
- 7 DRAINAGE LAYER
- 8 FILTER LAYER
- 9 CONCRETE SLAB
- 10 THINBED WATERPROOFING
- 11 PAVEMENT EMBEDDED IN CONCRETE
- 12 TERRACE DRAIN HL3100TH WITH FROST-PROOF FLAP WITH BITUMEN MEMBRANE 500x500 mm, LOAD CLASSIFICATION K3 (MAX 300 kg)
- 13 EXTENSION HL8500H WITH BITUMEN MEMBRANE 500x500 mm; INCL. O-RING
- 14 NO TIGHT CONNECTION BECAUSE OF DISCHARGE OF LEAKAGE WATER
- 15a EXTENSION HL8500 WITH FLANGE INCL. O-RING
- 15b SEALING KIT HL8300.M – WITH WITH LAMINATED FLEECE (500x500 mm)
- 16 EXTENSION WITH STAINLESS STEEL GRATE 138x138 mm AND STAINLESS STEEL FRAME 145x145 mm (INCLUDED IN HL3100TH)
- 17 JOINT FILLER
- 18 ASSEMBLY FOAM
- 19 DOWNPIPE THERMAL INSULATION
- 20 DOWNPIPE
- 21 FILL FREE SPACE WITH MINERAL WOOL
- 22 BITUMEN MEMBRANE \varnothing 750 mm

NOTICE:

TO HEAT THE DRAIN, YOU MAY USE HEATING KIT HKL156 WITH REGULATING HEAT SOURCE 40W/M; 230 V; (APR. 12-14W HEATING TAPE). (THE HEATING TAPE INCL. THERMAL INSULATION MUST BE PULLED ON THE DRAIN BODY BEFORE INSTALLATION)
 RECOMMENDED BOREHOLE DIAMETER IS \varnothing 220mm, \varnothing 220x220mm.
 DURING INSTALLATION TAKE CARE, THAT THE FLANGE POSITION IS ON THE LOWEST LEVEL OF DRAINAGE. WE RECOMMEND, TO SITE IT APPR. 1cm BELOW THE SCREED.
 TO AVOID CONDENSATE WATER TAKE CARE OF THERMAL INSULATION ON THE CONSTRUCTION SITE.

122113AZ