

ROOF WITH THERMAL INSULATION – COMPACT ROOF BITUMEN SHEETS
TERRACE, PAVEMENT IN CONCRETE

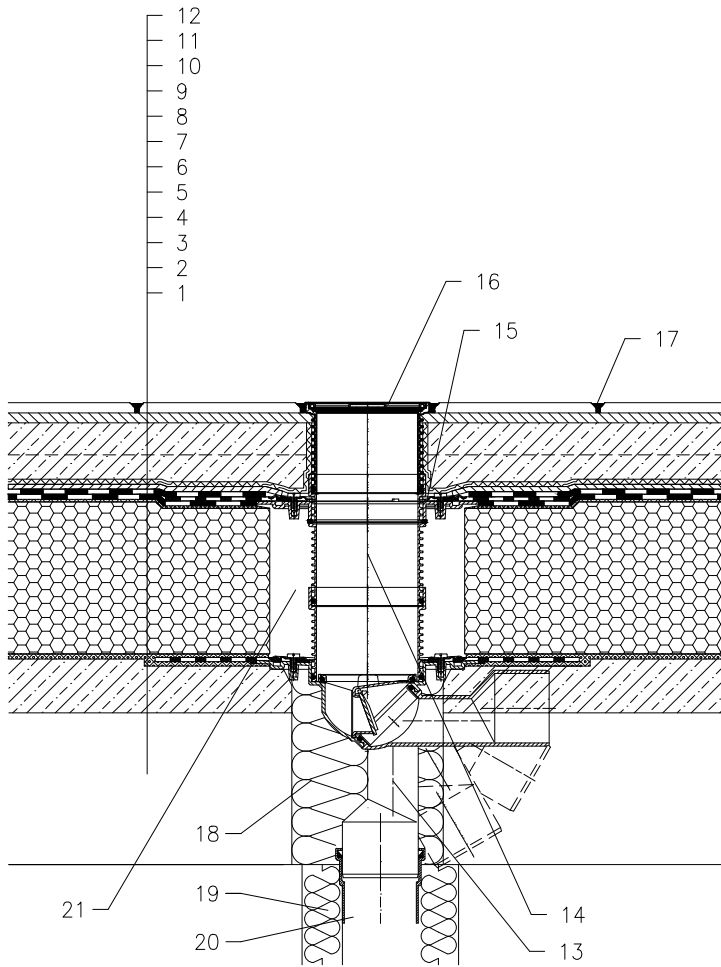

- 1 SUPPORT CONSTRUCTION
- 2 CONCRETE GRAVITY LAYER
- 3 HOT BITUMEN
- 4 THERMAL INSULATION – FOAMED GLASS
- 5 HOT BITUMEN
- 6 BITUMEN SHEET WATERPROOFING
- 7 BITUMEN SHEET WATERPROOFING
- 8 DRAINAGE LAYER
- 9 FILTER LAYER
- 10 CONCRETE SLAB
- 11 MORTAR BED OR GLUE
- 12 PAVEMENT
- 13 TERRACE DRAIN HL80H WITH FROST-PROOF FLAP
WITH BITUMEN MEMBRANE $\varnothing 400$ mm,
LOAD CLASSIFICATION K3 (MAX 300 kg)
- 14 EXTENSION HL85NH WITH BITUMEN MEMBRANE
 $\varnothing 400$ mm; INCL. O-RING, (HL340N)
- 15 NO TIGHT CONNECTION BECAUSE OF DISCHARGE OF LEAKAGE WATER
- 16 EXTENSION WITH STAINLESS STEEL GRATE 115x115 mm
AND PLASTIC FRAME 123x123 mm
(INCLUDED IN HL80H)
- 17 JOINT FILLER
- 18 ASSEMBLY FOAM
- 19 DOWNPIPE THERMAL INSULATION
- 20 DOWNPIPE
- 21 FILL FREE SPACE WITH MINERAL WOOL

NOTICE:

TO HEAT THE DRAIN, YOU MAY USE HEATING KIT HL82 WITH SELF-REGULATING HEAT SOURCE 18W/220V. (THE HEATING TAPE MUST BE WRAPPED AROUND THE DRAIN BODY BEFORE INSTALLATION).

RECOMMENDED BOREHOLE DIAMETER IS $\varnothing 185$ mm, $\varnothing 185 \times 340$ mm.

DURING INSTALLATION TAKE CARE, THAT THE FLANGE POSITION IS ON THE LOWEST LEVEL OF DRAINAGE. WE RECOMMEND, TO SITE IT APPR. 1cm BELOW THE SCREED.

TO AVOID CONDENSATE WATER TAKE CARE OF THERMAL INSULATION ON THE CONSTRUCTION SITE.

122111BX