

WARM ROOF – WALKABLE, CLASSICAL COMPACT STRUCTURE, BITUMEN SHEET WATERPROOFING  
PAVEMENT GLUED

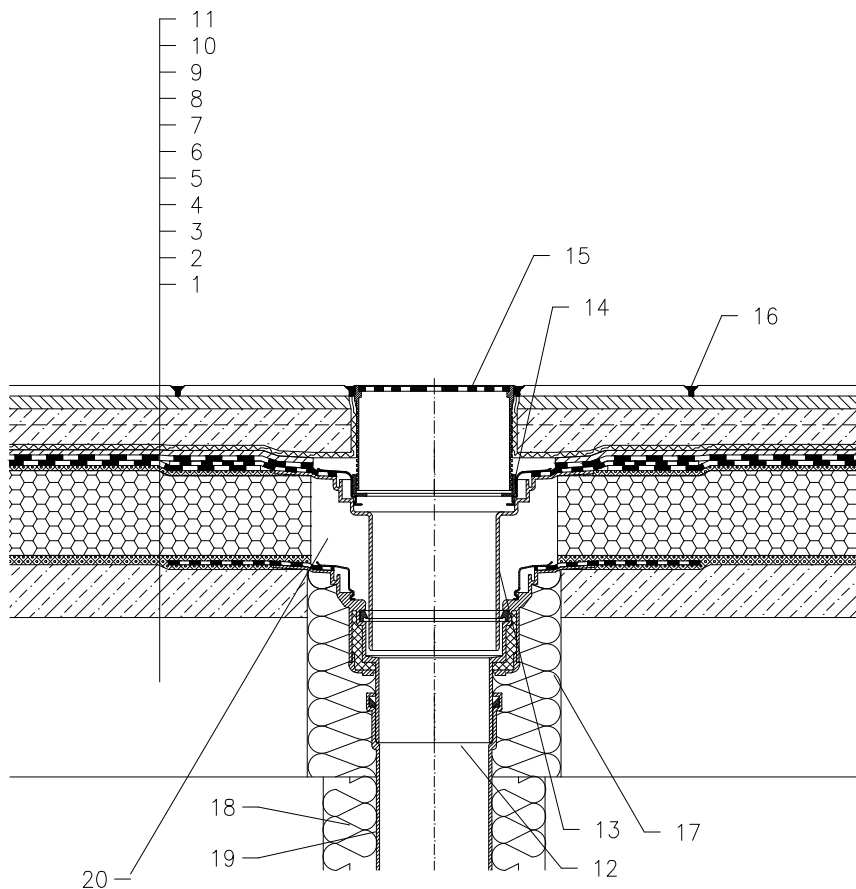

- 1 SUPPORT CONSTRUCTION
- 2 GRAVITY LAYER
- 3 HOT BITUMEN
- 4 THERMAL INSULATION – CELLULAR GLASS
- 5 HOT BITUMEN
- 6 BITUMEN SHEET WATERPROOFING SOLID GLUED
- 7 DRAINAGE LAYER
- 8 FILTER LAYER
- 9 CONCRETE SLAB
- 10 MORTAR BED OR GLUE
- 11 PAVEMENT
- 12 FLAT-ROOF DRAIN HL62BH WITH INSULATED DRAIN BODY, WITH FACTORY WELDED BITUMEN MEMBRANE  $\varnothing$ 500 mm, THICKNESS 4 mm
- 13 EXTENSION HL65H WITH FLANGE AND FACTORY WELDED BITUMEN MEMBRANE  $\varnothing$ 500 mm, THICKNESS 4 mm
- 14 ADAPTER 062B.3E (INCL. WITH HL62BH)
- 15 GRATING HL66.9 WITH STAINLESS STEEL GRATE 150x150 mm CHARGEABLE TO 300 kg (INCL. WITH HL62BH)
- 16 JOINT FILLER
- 17 ASSEMBLY FOAM
- 18 DOWNPIPE THERMAL INSULATION
- 19 DOWNPIPE
- 20 FILL FREE SPACE WITH MINERAL WOOL

NOTE:

FLAT-ROOF DRAIN HL62.1BH HEATED (230V, 10-30 WATTS) CAN BE USED.  
ASSEMBLY INLET:  $\varnothing$ 255 mm, OR 255 x 380 mm

122111B