

NON-INSULATED – GREEN ROOF, BITUMEN SHEET WATERPROOFING
INTENSIVE GRASSING

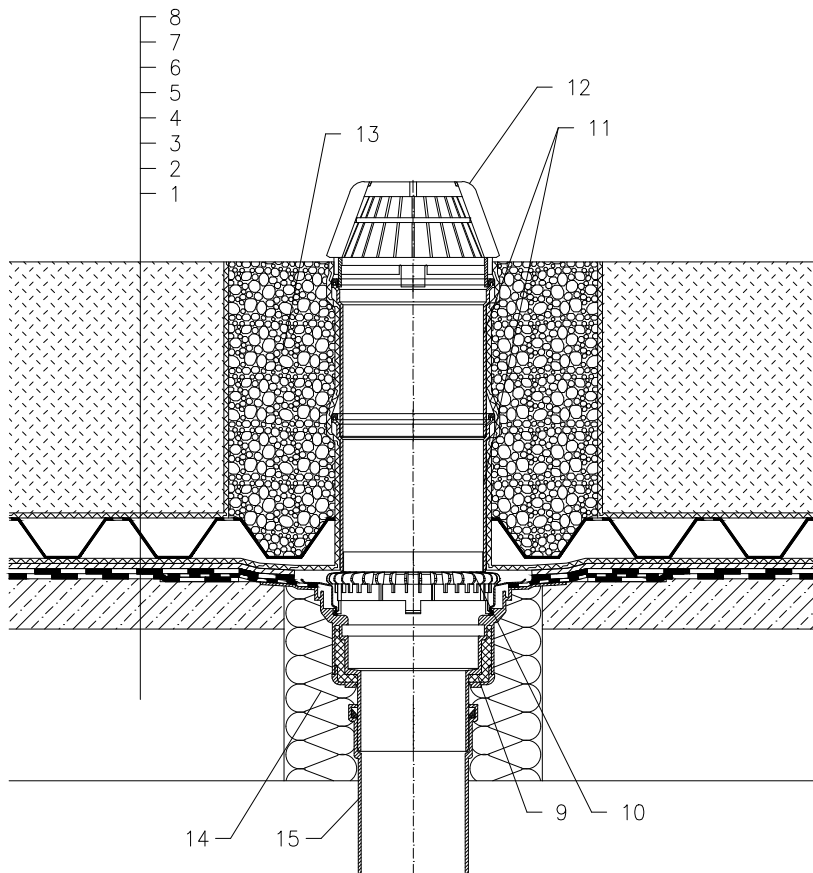

- 1 SUPPORT CONSTRUCTION
- 2 GRAVITY LAYER
- 3 BITUMEN SHEET WATERPROOFING WITH FLL CERTIFICATE
- 4 DRAINAGE LAYER
- 5 FILTER LAYER
- 6 WATER ACCUMULATING LAYER
- 7 FILTER LAYER
- 8 VEGETATION LAYER (OVER 200 mm)
- 9 FLAT-ROOF DRAIN HL62H WITH INSULATED DRAIN BODY, WITH FACTORY WELDED BITUMEN MEMBRANE \varnothing 500 mm, THICKNESS 4 mm
- 10 GRAVEL GUARD HL160
- 11 EXTENSION HL350
- 12 DOMED PLASTIC GRATE \varnothing 180 mm (INCL. WITH HL62H)
- 13 GRANULAR FILL
- 14 ASSEMBLY FOAM
- 15 DOWNPIPE

NOTE:

FLAT-ROOF DRAIN HL62.1H HEATED (230V, 10-30 WATTS) CAN BE USED.

ASSEMBLY INLET: \varnothing 255 MM, ALTERNATIVELY 255X380 MM

112321