

ROOFS WITHOUT THERMAL INSULATION – EXTENSIVE GRASSING, BITUMEN SHEETS

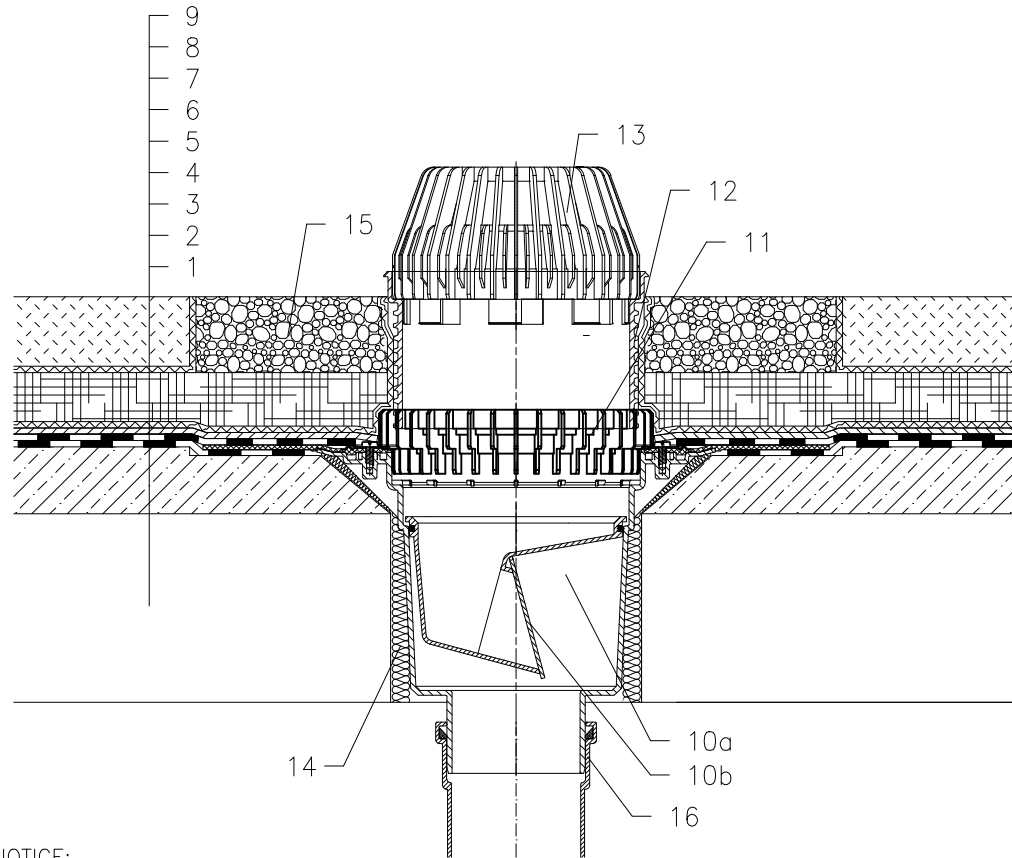

- 1 SUPPORT CONSTRUCTION
- 2 CONCRETE GRAVITY LAYER
- 3 BITUMEN SHEET WATERPROOFING
NON SOLID GLUED OR LAID LOOSE
- 4 BITUMEN SHEET WATERPROOFING
- 5 DRAINAGE LAYER
- 6 FILTER LAYER
- 7 WATER ACCUMULATING LAYER
- 8 FILTER LAYER
- 9 VEGETATION LAYER (UNDER 200mm)
- 10a DRAIN BODY HL616HK
WITH BITUMEN MEMBRANE \varnothing 500 mm
- 10b FROST-PROOF FLAP HL0606.3E
(NOT INCLUDED IN HL616HK)
- 11 DRAINAGE RING HL190
- 12 EXTENSION HL620
- 13 LEAF STRAINER HL195
- 14 ASSEMBLY FOAM
- 15 GRANULAR FILL
- 16 DOWNPIPE

NOTICE:

TO HEAT THE DRAIN, YOU MAY USE HEATING KIT HL609 WITH SELF-REGULATING HEAT SOURCE 36W/230V. (THE HEATING TAPE MUST BE WRAPPED AROUND THE DRAIN BODY BEFORE INSTALLATION).
 RECOMMENDED BOREHOLE DIAMETER IS \varnothing 290mm, OR: ∇ 290x290mm
 DURING INSTALLATION TAKE CARE, THAT THE FLANGE POSITION IS ON THE LOWEST LEVEL OF DRAINAGE. WE RECOMMEND, TO SITE IT APPR. 1cm BELOW THE SCREED.
 TO AVOID CONDENSATE WATER TAKE CARE OF THERMAL INSULATION ON THE CONSTRUCTION SITE.

112311Y