

NON-INSULATED – CAR PARK, COMPACT STRUCTURE, BITUMEN SHEET WATERPROOFING

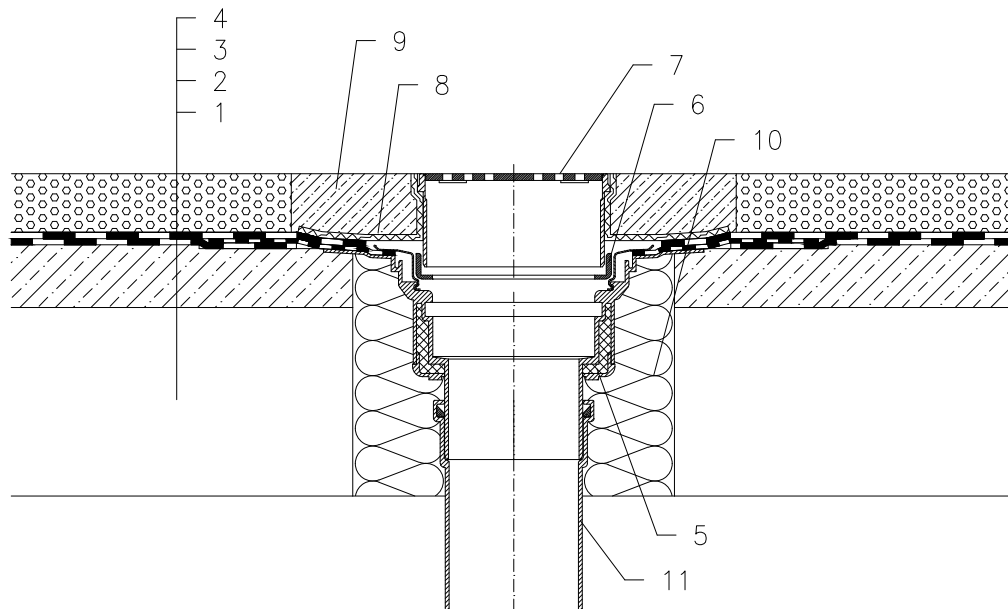

- 1 SUPPORT CONSTRUCTION
- 2 GRAVITY LAYER
- 3 BITUMEN SHEET WATERPROOFING SOLID GLUED
- 4 CAST ASPHALT
- 5 FLAT-ROOF DRAIN HL62H WITH INSULATED DRAIN BODY, WITH FACTORY WELDED BITUMEN MEMBRANE ϕ 500 mm, THICKNESS 4 mm
- 6 ADAPTER 062B.3E
- 7 GRATING HL66 (TRUNCATABLE) WITH STAINLESS STEEL FRAME AND SECURED STAINLESS STEEL GRATE, MAX. LOAD 1,5 t
- 8 DILATATION LAYER
- 9 CONCRETE BELT 1000 X 1000 X 100 mm
- 10 ASSEMBLY FOAM
- 11 DOWNPIPE

NOTE:

FLAT-ROOF DRAIN HL62.1H HEATED (230V, 10-30 WATTS) CAN BE USED.

ASSEMBLY INLET: ϕ 255 MM, ALTERNATIVELY 255X380 MM

11222