

## ROOFS WITHOUT THERMAL INSULATION – TERRACE, PAVEMENT IN SUBBASE, BITUMEN SHEETS

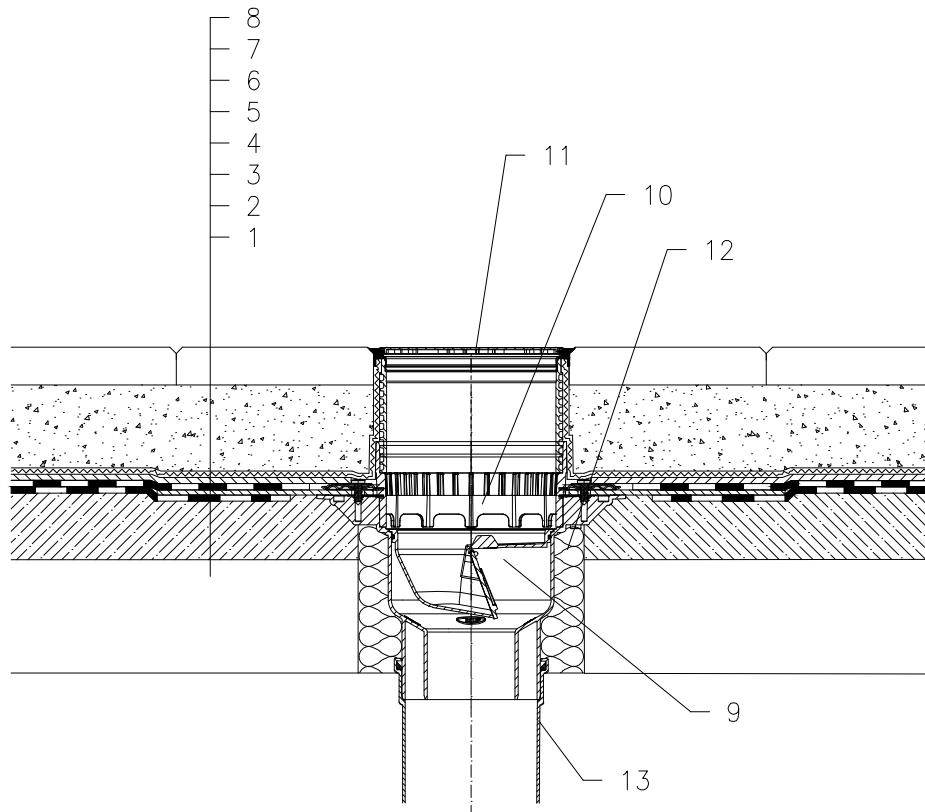

- 1 SUPPORT CONSTRUCTION
- 2 CONCRETE GRAVITY LAYER
- 3 BITUMEN SHEET WATERPROOFING  
NON SOLID GLUED OR LAID LOOSE
- 4 BITUMEN SHEET WATERPROOFING
- 5 DRAINAGE LAYER
- 6 FILTER LAYER
- 7 SAND SUBBASE
- 8 PAVEMENT
- 9 TERRACE DRAIN HL3100THK WITH FROST-PROOF FLAP  
WITH BITUMEN MEMBRANE 500x500 mm,  
LOAD CLASSIFICATION K3 (MAX 300 kg)
- 10 DRAINAGE RING HL150
- 11 EXTENSION WITH STAINLESS STEEL GRATE 138x138 mm  
AND STAINLESS STEEL FRAME 145x145 mm  
(INCLUDED IN HL3100THK)
- 12 ASSEMBLY FOAM
- 13 DOWNPIPE

### NOTICE:

TO HEAT THE DRAIN, YOU MAY USE HEATING KIT HKL156 WITH REGULATING HEAT SOURCE 40W/M; 230 V; (APR. 12-14W HEATING TAPE). (THE HEATING TAPE INCL. THERMAL INSULATION MUST BE PULLED ON THE DRAIN BODY BEFORE INSTALLATION)  
RECOMMENDED BOREHOLE DIAMETER IS  $\varnothing 220\text{mm}$ ,  $\varnothing 220 \times 220\text{mm}$ .  
DURING INSTALLATION TAKE CARE, THAT THE FLANGE POSITION IS ON THE LOWEST LEVEL OF DRAINAGE. WE RECOMMEND, TO SITE IT APPR. 1cm BELOW THE SCREED.  
TO AVOID CONDENSATE WATER TAKE CARE OF THERMAL INSULATION ON THE CONSTRUCTION SITE.

112121Z