

NON-INSULATED – WALKABLE, PAVEMENT GLUED, BITUMEN SHEET WATERPROOFING

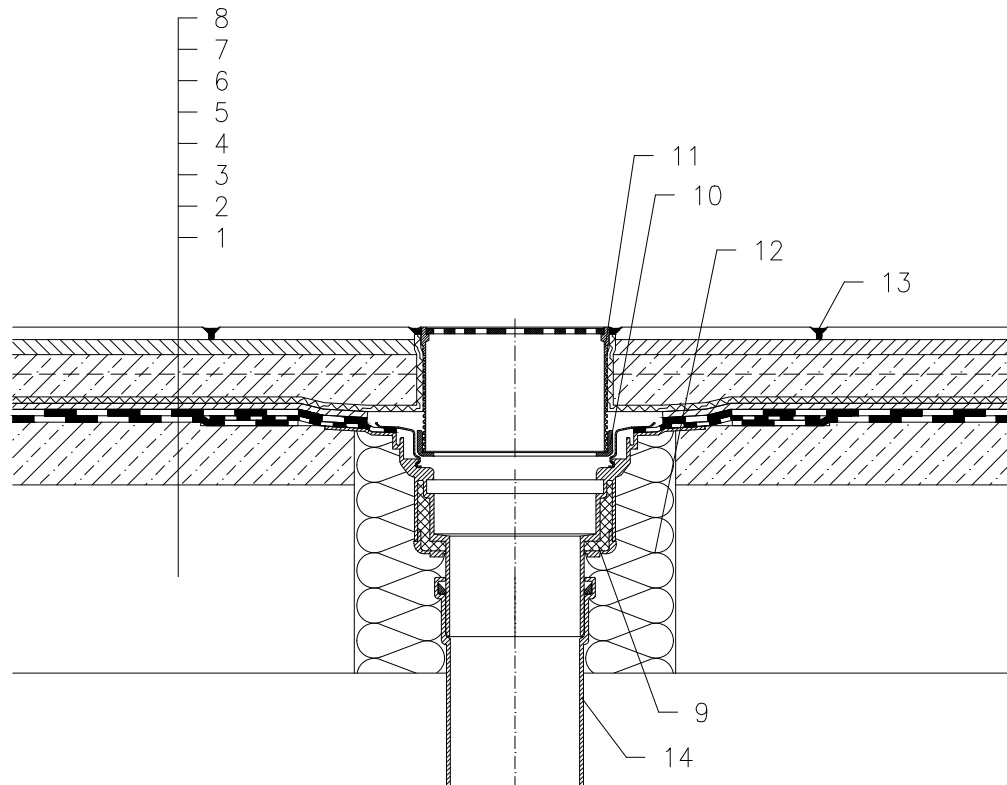

- 1 SUPPORT CONSTRUCTION
- 2 GRAVITY LAYER
- 3 BITUMEN SHEET WATERPROOFING NON-SOLID GLUED OR LAID LOOSE
- 4 DRAINAGE LAYER
- 5 FILTER LAYER
- 6 CONCRETE SLAB WITH THINBED WATERPROOFING
- 7 MORTAR BED OR GLUE
- 8 PAVEMENT
- 9 FLAT-ROOF DRAIN HL62BH WITH INSULATED DRAIN BODY, WITH FACTORY WELDED BITUMEN MEMBRANE \varnothing 500 mm, THICKNESS 4 mm
- 10 ADAPTER O62B.3E (INCL. WITH HL62BH)
- 11 GRATING HL66.9 WITH STAINLESS STEEL GRATE 150x150 mm, CHARGEABLE TO 300 kg (INCL. WITH HL62BH)
- 12 ASSEMBLY FOAM
- 13 JOINT FILLER
- 14 DOWNPIPE

NOTE:

FLAT-ROOF DRAIN HL62.1BH HEATED (230V, 10-30 WATTS) CAN BE USED.

ASSEMBLY INLET: \varnothing 255 MM, ALTERNATIVELY 255X380 MM

112111