

NON-INSULATED – GLUED SYSTEM, PLASTIC FOIL WATERPROOFING

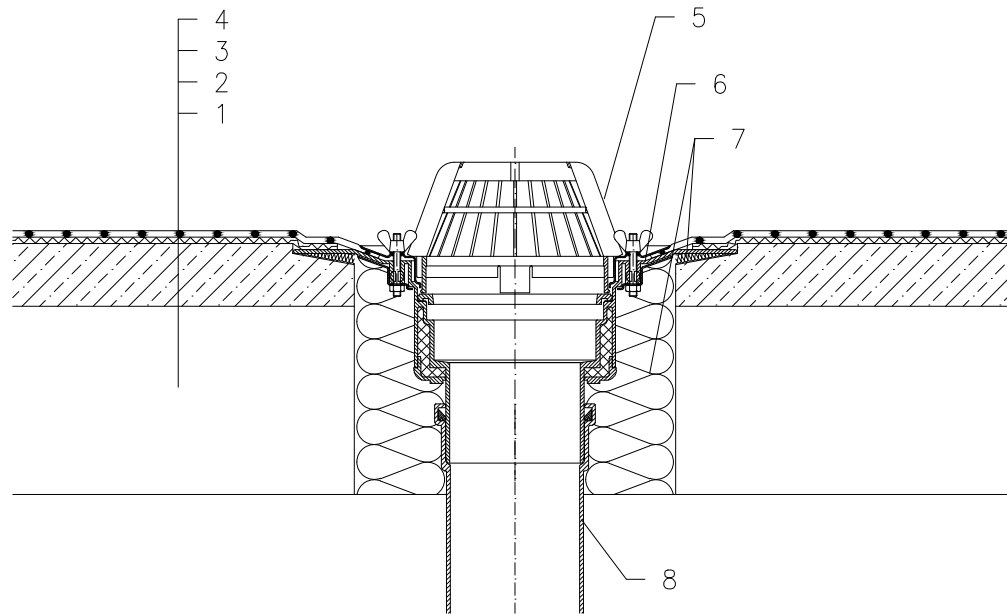

- 1 SUPPORT CONSTRUCTION
- 2 GRAVITY LAYER
- 3 DILATATION LAYER
- 4 PLASTIC FOIL WATERPROOFING NON-SOLID GLUED
- 5 FLAT-ROOF DRAIN HL62 WITH INSULATED DRAIN BODY, FLANGE AND STAINLESS STEEL CLAMPING RING, DOMED PLASTIC GRATE $\phi 180$ mm, (FOR PVC SHEETINGS FLAT-ROOF DRAIN HL62P; FOR FPO SHEETINGS BASED ON PP FLAT-ROOF DRAIN HL62F)
- 6 SEALING PACKING, (SEE ACCESSORIES)
- 7 ASSEMBLY FOAM
- 8 DOWNPIPE

NOTE:

FLAT-ROOF DRAIN HL62.1, (FOR PVC SHEETINGS FLAT-ROOF DRAIN HL62.1P; FOR FPO SHEETINGS BASED ON PP FLAT-ROOF DRAIN HL62.1F) HEATED (230V, 10-30 WATTS) CAN BE USED.
ASSEMBLY INLET: $\phi 255$ MM, ALTERNATIVELY 255X380 MM

111121