

WARM ROOF – CAR PARK, COMBINED COMPACT STRUCTURE, BITUMEN SHEET WATERPROOFING

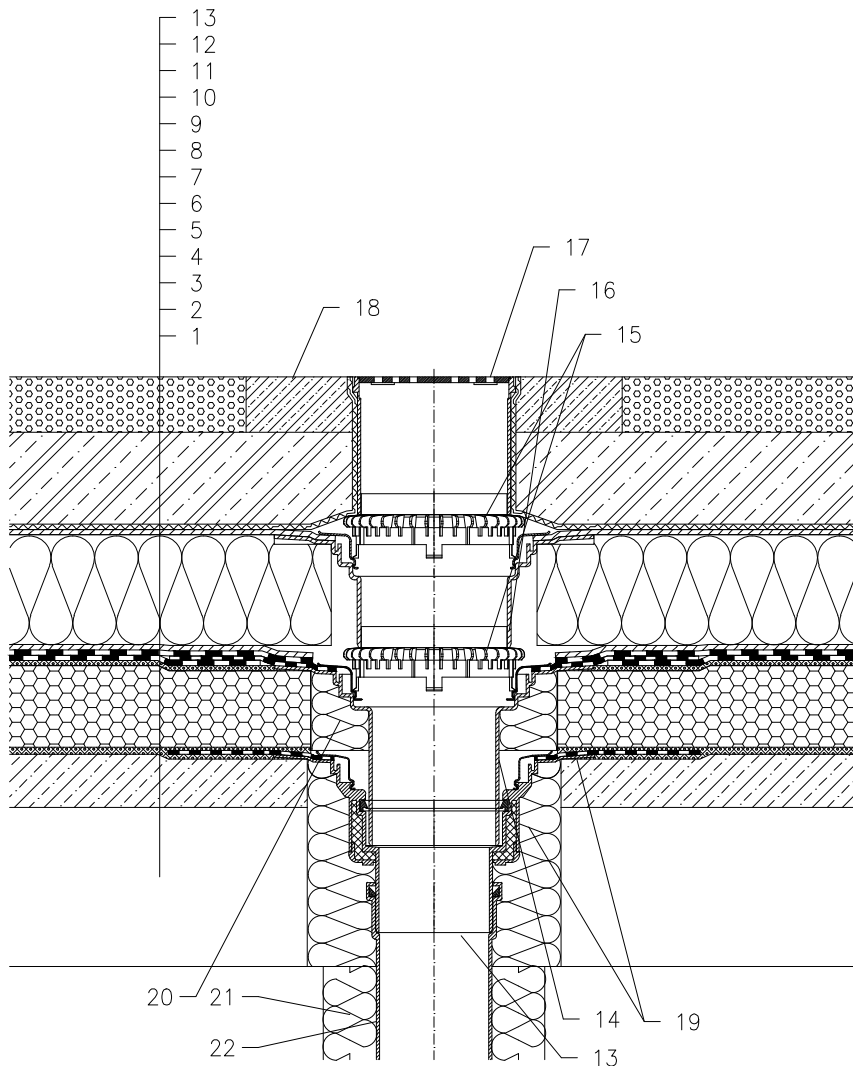

- 1 SUPPORT CONSTRUCTION
- 2 GRAVITY LAYER
- 3 HOT BITUMEN
- 4 THERMAL INSULATION – CELLULAR GLASS
- 5 HOT BITUMEN
- 6 BITUMEN SHEET WATERPROOFING SOLID GLUED
- 7 DRAINAGE LAYER
- 8 THERMAL INSULATION FROM XPS
- 9 DRAINAGE LAYER
- 10 FILTER LAYER
- 11 REINFORCED CONCRETE SLAB
- 12 CAST ASPHALT
- 13 FLAT-ROOF DRAIN HL62H WITH INSULATED DRAIN BODY, WITH FACTORY WELDED BITUMEN MEMBRANE ϕ 500 mm, THICKNESS 4 mm
- 14 EXTENSION HL65H WITH FLANGE AND FACTORY WELDED BITUMEN MEMBRANE ϕ 500 mm, THICKNESS 4 mm
- 15 GRAVEL GUARD HL160
- 16 EXTENSION HL350.0 WITH FLANGE AND WATERPROOFING KIT HL84.0
- 17 GRATING HL66 (TRUNCATABLE) WITH STAINLESS STEEL FRAME AND SECURED STAINLESS STEEL GRATE, MAX. LOAD 1,5 t
- 18 CONCRETE BELT 1000 X 1000 X 100 mm
- 19 ASSEMBLY FOAM
- 20 FILL FREE SPACE WITH MINERAL WOOL
- 21 DOWNPIPE THERMAL INSULATION
- 22 DOWNPIPE

NOTE:

FLAT-ROOF DRAIN HL62.1H HEATED (230V, 10-30 WATTS) CAN BE USED.

ASSEMBLY INLET: ϕ 255 MM, ALTERNATIVELY 255X380 MM

14221B