

ROOF WITH THERMAL INSULATION – COMBINED ORDER OF LAYERS, COMPACT ROOF VARIANT, PAVEMENT IN CONCRETE BITUMEN SHEETS

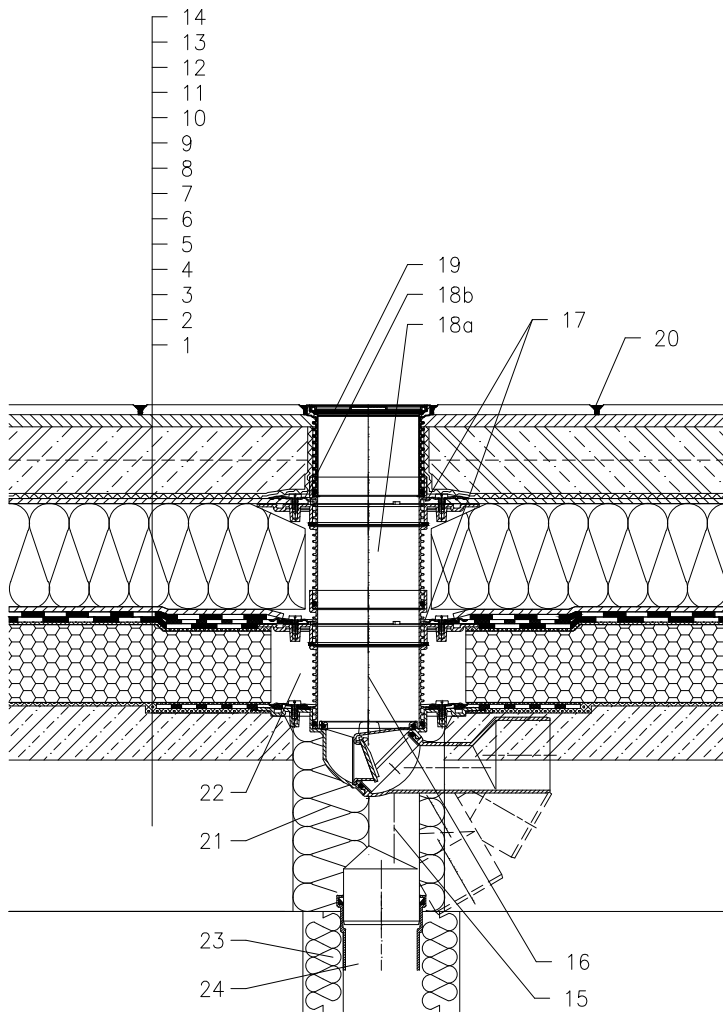

- 1 SUPPORT CONSTRUCTION
- 2 CONCRETE GRAVITY LAYER
- 3 HOT BITUMEN
- 4 THERMAL INSULATION – FOAMED GLASS
- 5 HOT BITUMEN
- 6 BITUMEN SHEET WATERPROOFING
- 7 BITUMEN SHEET WATERPROOFING
- 8 DRAINAGE LAYER
- 9 XPS THERMAL INSULATION
- 10 DRAINAGE LAYER
- 11 FILTER LAYER
- 12 CONCRETE SLAB
- 13 MORTAR BED OR GLUE
- 14 PAVEMENT
- 15 TERRACE DRAIN HL80H WITH FROST-PROOF FLAP WITH BITUMEN MEMBRANE  $\varnothing 400$  mm, LOAD CLASSIFICATION K3 (MAX 300 kg)
- 16 EXTENSION HL85NH WITH BITUMEN MEMBRANE  $\varnothing 400$  mm; INCL. O-RING, (HL340N)
- 17 NO TIGHT CONNECTION BECAUSE OF DISCHARGE OF LEAKAGE WATER
- 18a EXTENSION HL85N WITH FLANGE INCL. O-RING, (HL340N)
- 18b SEALING KIT HL83.0
- 19 EXTENSION WITH STAINLESS STEEL GRATE 115x115 mm AND PLASTIC FRAME 123x123 mm (INCLUDED IN HL80H)
- 20 JOINT FILLER
- 21 ASSEMBLY FOAM
- 22 FILL FREE SPACE WITH MINERAL WOOL
- 23 DOWNPIPE THERMAL INSULATION
- 24 DOWNPIPE

NOTICE:

TO HEAT THE DRAIN, YOU MAY USE HEATING KIT HL82 WITH SELF-REGULATING HEAT SOURCE 18W/220V. (THE HEATING TAPE MUST BE WRAPPED AROUND THE DRAIN BODY BEFORE INSTALLATION).  
 RECOMMENDED BOREHOLE DIAMETER IS  $\varnothing 185$ mm,  $\varnothing 185 \times 340$ mm.  
 DURING INSTALLATION TAKE CARE, THAT THE FLANGE POSITION IS ON THE LOWEST LEVEL OF DRAINAGE. WE RECOMMEND, TO SITE IT APPR. 1cm BELOW THE SCREED.  
 TO AVOID CONDENSATE WATER TAKE CARE OF THERMAL INSULATION ON THE CONSTRUCTION SITE.

142111BX