

WARM ROOF – GREEN ROOF, REVERSE LAYER ORDER STRUCTURE, BITUMEN SHEET WATERPROOFING  
EXTENSIVE GRASSING

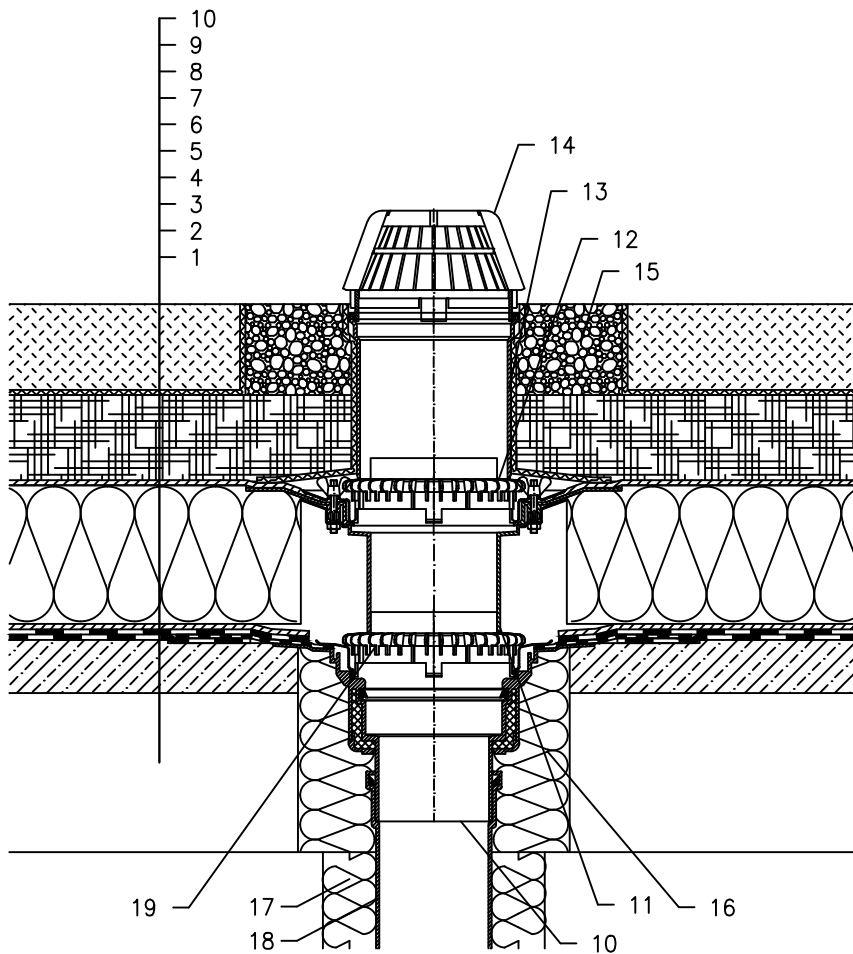

- 1 SUPPORT CONSTRUCTION
- 2 GRAVITY LAYER
- 3 BITUMEN SHEET WATERPROOFING NON-SOLID GLUED OR LAID LOOSE
- 4 DRAINAGE LAYER
- 5 THERMAL INSULATION FROM XPS
- 6 DRAINAGE LAYER
- 7 WATER ACCUMULATING LAYER
- 8 FILTER LAYER
- 9 VEGETATION LAYER (UNDER 200 mm)
- 10 FLAT-ROOF DRAIN HL62H WITH INSULATED DRAIN BODY, WITH FACTORY WELDED BITUMEN MEMBRANE  $\varnothing$ 500 mm, THICKNESS 4 mm
- 11 EXTENSION HL65 WITH FLANGE, STAINLESS STEEL CLAMPING RING
- 12 GRAVEL GUARD HL160
- 13 EXTENSION HL350
- 14 DOMED PLASTIC GRATE  $\varnothing$ 180 mm (INCL. WITH HL62H)
- 15 GRANULAR FILL
- 16 ASSEMBLY FOAM
- 17 DOWNPIPE THERMAL INSULATION
- 18 DOWNPIPE
- 19 DRAINAGE ELEMENT HL161

NOTE:

FLAT-ROOF DRAIN HL62.1H HEATED (230V, 10-30 WATTS) CAN BE USED.

ASSEMBLY INLET:  $\varnothing$ 255 mm, OR 255 x 380 mm

132311