

WARM ROOF – CAR PARK, REVERSE LAYER ORDER STRUCTURE, PLASTIC FOIL WATERPROOFING

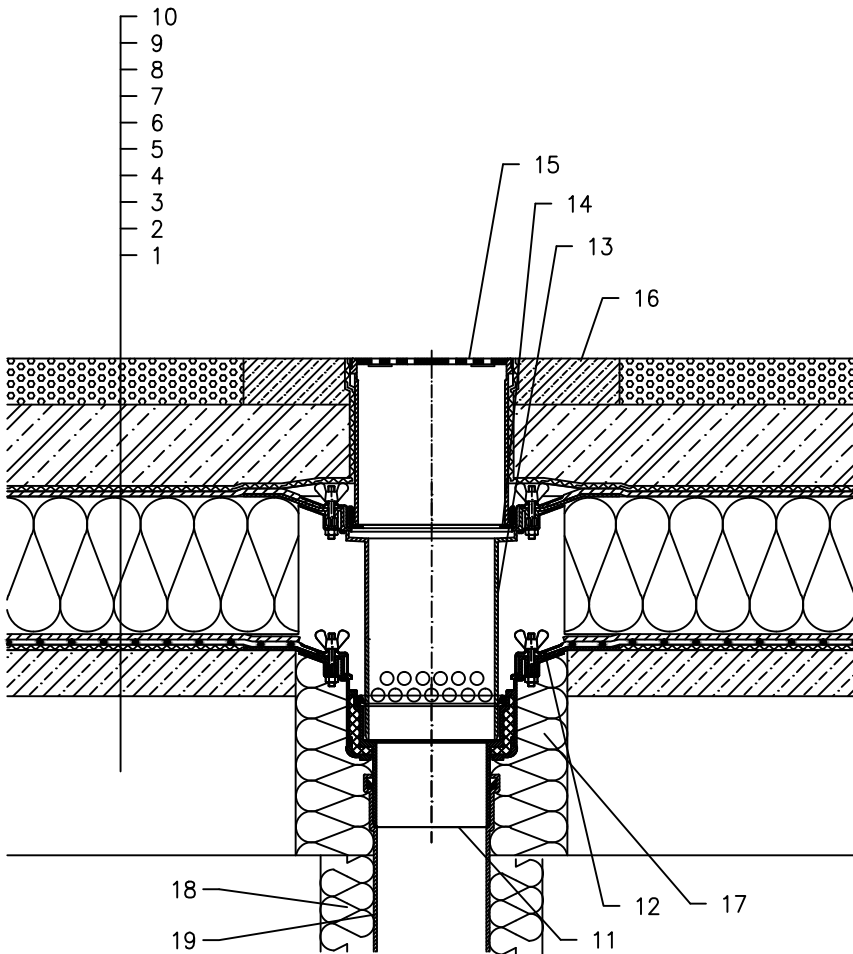

- 1 SUPPORT CONSTRUCTION
- 2 GRAVITY LAYER
- 3 DILATATION LAYER
- 4 PLASTIC FOIL WATERPROOFING LAID LOOSE
- 5 DILATATION AND DRAINAGE LAYER
- 6 THERMAL INSULATION FROM XPS
- 7 DRAINAGE LAYER
- 8 FILTER LAYER
- 9 REINFORCED CONCRETE SLAB
- 10 CAST ASPHALT
- 11 FLAT-ROOF DRAIN HL62 WITH INSULATED DRAIN BODY, FLANGE AND STAINLESS STEEL CLAMPING RING
(FOR PVC SHEETINGS FLAT -ROOF DRAIN HL62P; FOR FPO SHEETINGS BASED ON PP FLAT -ROOF DRAIN HL62F)
- 12 SEALING PACKING (SEE-ACCESSORIES)
- 13 EXTENSION HL65 WITH FLANGE, STAINLESS STEEL CLAMPING RING
- 14 ADAPTER O62B.3E
- 15 GRATING HL66 (TRUNCATABLE) WITH STAINLESS STEEL FRAME AND SECURED STAINLESS STEEL GRATE, MAX. LOAD 1,5 t
- 16 CONCRETE BELT 1000 X 1000 X 100 mm
- 17 ASSEMBLY FOAM
- 18 DOWNPIPE THERMAL INSULATION
- 19 DOWNPIPE

NOTE:

FLAT-ROOF DRAIN HL62.1(FOR PVC SHEETINGS FLAT -ROOF DRAIN HL62.1P;
FOR FPO SHEETINGS BASED ON PP FLAT -ROOF DRAIN HL62.1F)HEATED (230V,
10-30 WATTS) CAN BE USED.
ASSEMBLY INLET: Ø255 mm, OR 255 x 380 mm