

ROOF WITH THERMAL INSULATION – PAVERS ON STANDS, REVERSE ORDER OF LAYERS  
PLASTIC FOIL

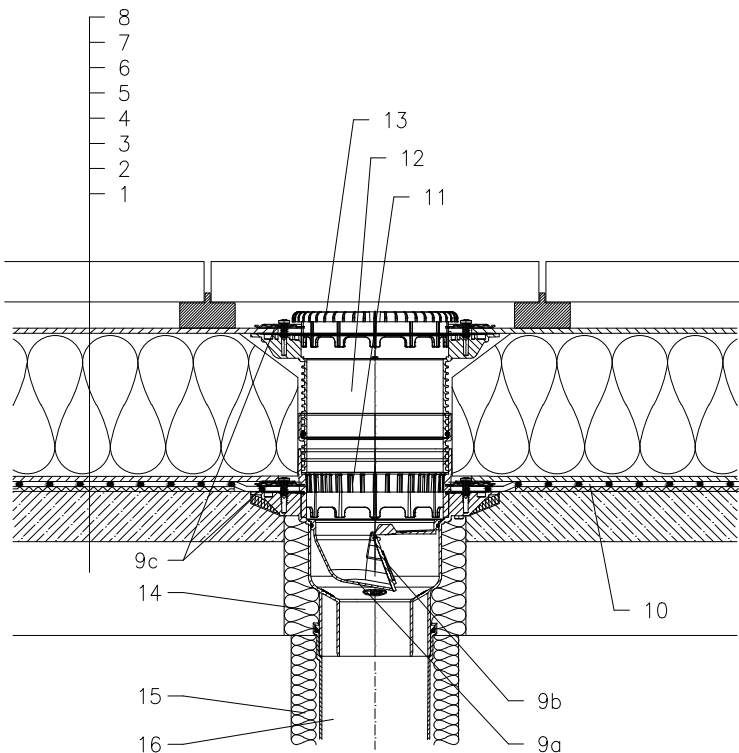

- 1 SUPPORT CONSTRUCTION
- 2 CONCRETE GRAVITY LAYER
- 3 SEPARATING LAYER
- 4 PLASTIC FOIL WATERPROOFING
- 5 SEPARATING AND DRAINAGE LAYER
- 6 XPS THERMAL INSULATION
- 7 SEPARATION LAYER
- 8 PAVERS ON STANDS
- 9a DRAIN BODY HL3100TK WITH FLANGE
- 9b FROST-PROOF FLAP HL05100.4E  
(NOT INCLUDED IN HL3100TK)
- 9c SEALING KIT HL8300.0 – WITHOUT SHEETING,  
(ALL-PURPOSE FOR UNRUFFED ROOF SHEETINGS)  
(alternative HL8300.P – WHEN USING PVC SHEETINGS)
- 10 PRE-CUT PART FOR SEALING COLLAR, SEE TOPIC "ATTACHEMENTS"
- 11 DRAINAGE RING HL150
- 12 EXTENSION HL8500 WITH FLANGE  
INCL. O-RING
- 13 FLAT LEAF STRAINER HL151  
(NOT INCLUDED IN HL3100TK)
- 14 ASSEMBLY FOAM
- 15 DOWNPIPE THERMAL INSULATION
- 16 DOWNPIPE

NOTICE:

TO HEAT THE DRAIN, YOU MAY USE HEATING KIT HKL156 WITH REGULATING HEAT SOURCE 40W/M; 230 V; (APR. 12-14W HEATING TAPE). (THE HEATING TAPE INCL. THERMAL INSULATION MUST BE PULLED ON THE DRAIN BODY BEFORE INSTALLATION)  
RECOMMENDED BOREHOLE DIAMETER IS  $\varnothing 220\text{mm}$ ,  $\varnothing 220 \times 220\text{mm}$ .  
DURING INSTALLATION TAKE CARE, THAT THE FLANGE POSITION IS ON THE LOWEST LEVEL OF DRAINAGE. WE RECOMMEND, TO SITE IT APPR. 1cm BELOW THE SCREED.  
TO AVOID CONDENSATE WATER TAKE CARE OF THERMAL INSULATION ON THE CONSTRUCTION SITE.

132132AZ