

WARM ROOF – WALKABLE, REVERSE LAYER ORDER STRUCTURE, BITUMEN SHEET WATERPROOFING  
PAVEMENT ON STANDS

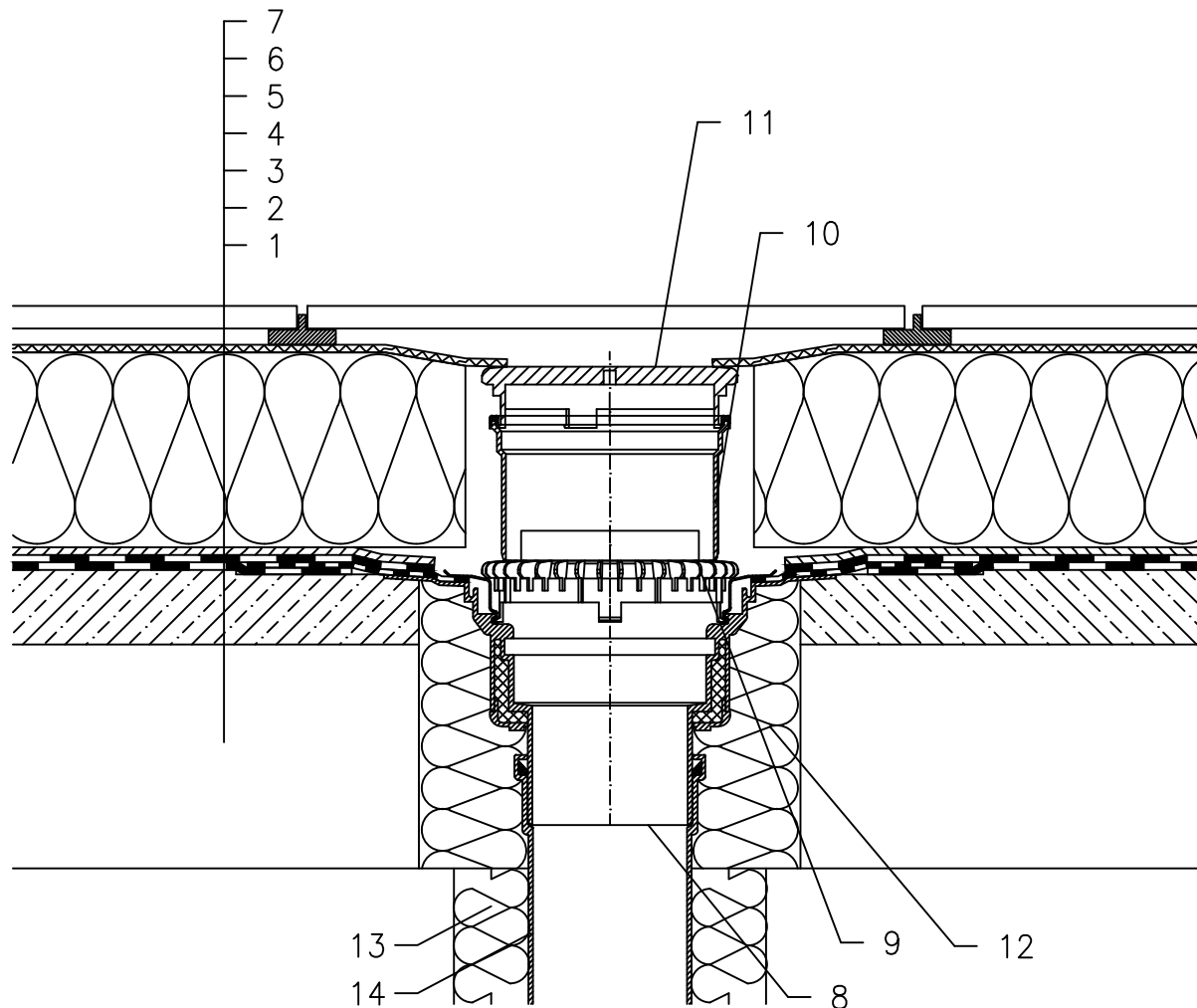

- 1 SUPPORT CONSTRUCTION
- 2 GRAVITY LAYER
- 3 BITUMEN SHEET WATERPROOFING NON-SOLID GLUED OR LAID LOOSE
- 4 DRAINAGE LAYER
- 5 THERMAL INSULATION FROM XPS
- 6 DILATATION LAYER
- 7 PAVEMENT ON STANDS
- 8 FLAT-ROOF DRAIN HL62H WITH INSULATED DRAIN BODY, WITH FACTORY WELDED BITUMEN MEMBRANE  $\varnothing$ 500 mm, THICKNESS 4 mm
- 9 GRAVEL GUARD HL160
- 10 EXTENSION HL350
- 11 FLAT GRATE HL170 (SUPPLIED INLET)
- 12 ASSEMBLY FOAM
- 13 DOWNPIPE THERMAL INSULATION
- 14 DOWNPIPE

NOTE:

FLAT-ROOF DRAIN HL62.1H HEATED (230V, 10-30 WATTS) CAN BE USED.

ASSEMBLY INLET:  $\varnothing$ 255 mm, OR 255 x 380 mm