

WARM ROOF – LOADED SYSTEM, REVERSE LAYER ORDER STRUCTURE  
 PLASTIC FOIL WATERPROOFING

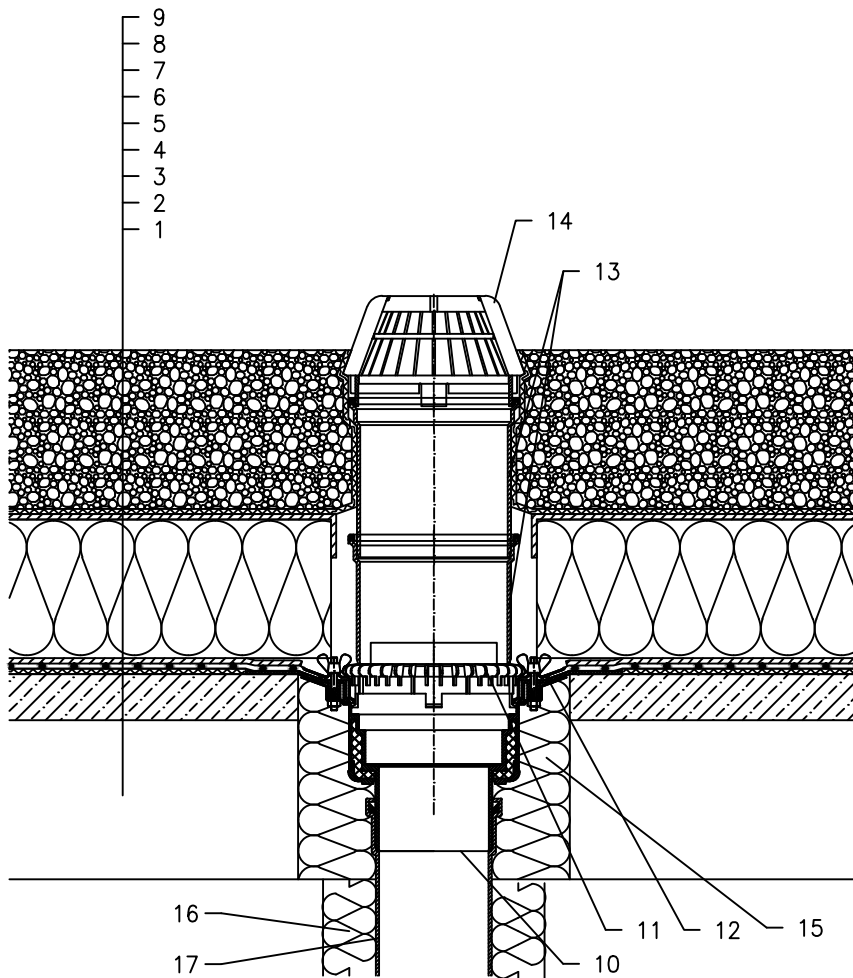

- 1 SUPPORT CONSTRUCTION
- 2 GRAVITY LAYER
- 3 DILATATION LAYER
- 4 PLASTIC FOIL WATERPROOFING LAID LOOSE
- 5 DRAINAGE LAYER
- 6 THERMAL INSULATION FROM XPS
- 7 DRAINAGE LAYER
- 8 FILTER LAYER
- 9 STABILIZING LAYER
- 10 FLAT-ROOF DRAIN HL62 WITH INSULATED DRAIN BODY, FLANGE AND STAINLESS STEEL CLAMPING RING (FOR PVC SHEETINGS FLAT -ROOF DRAIN HL62P; FOR FPO SHEETINGS BASED ON PP FLAT -ROOF DRAIN HL62F)
- 11 GRAVEL GUARD HL160
- 12 SEALING PACKING (SEE-ACCESSORIES)
- 13 EXTENSION HL350
- 14 DOMED PLASTIC GRATE  $\phi$ 180 mm (INCL. WITH HL62)
- 15 ASSEMBLY FOAM
- 16 DOWNPIPE THERMAL INSULATION
- 17 DOWNPIPE

NOTE:  
 FLAT-ROOF DRAIN HL62.1(FOR PVC SHEETINGS FLAT -ROOF DRAIN HL62.1P;  
 FOR FPO SHEETINGS BASED ON PP FLAT -ROOF DRAIN HL62.1F)HEATED (230V,  
 10-30 WATTS) CAN BE USED.  
 ASSEMBLY INLET:  $\phi$ 255 mm, OR 255 x 380 mm