

WARM ROOF – GREEN ROOF, CLASSICAL COMPACT STRUCTURE, BITUMEN SHEET WATERPROOFING
INTENSIVE GRASSING

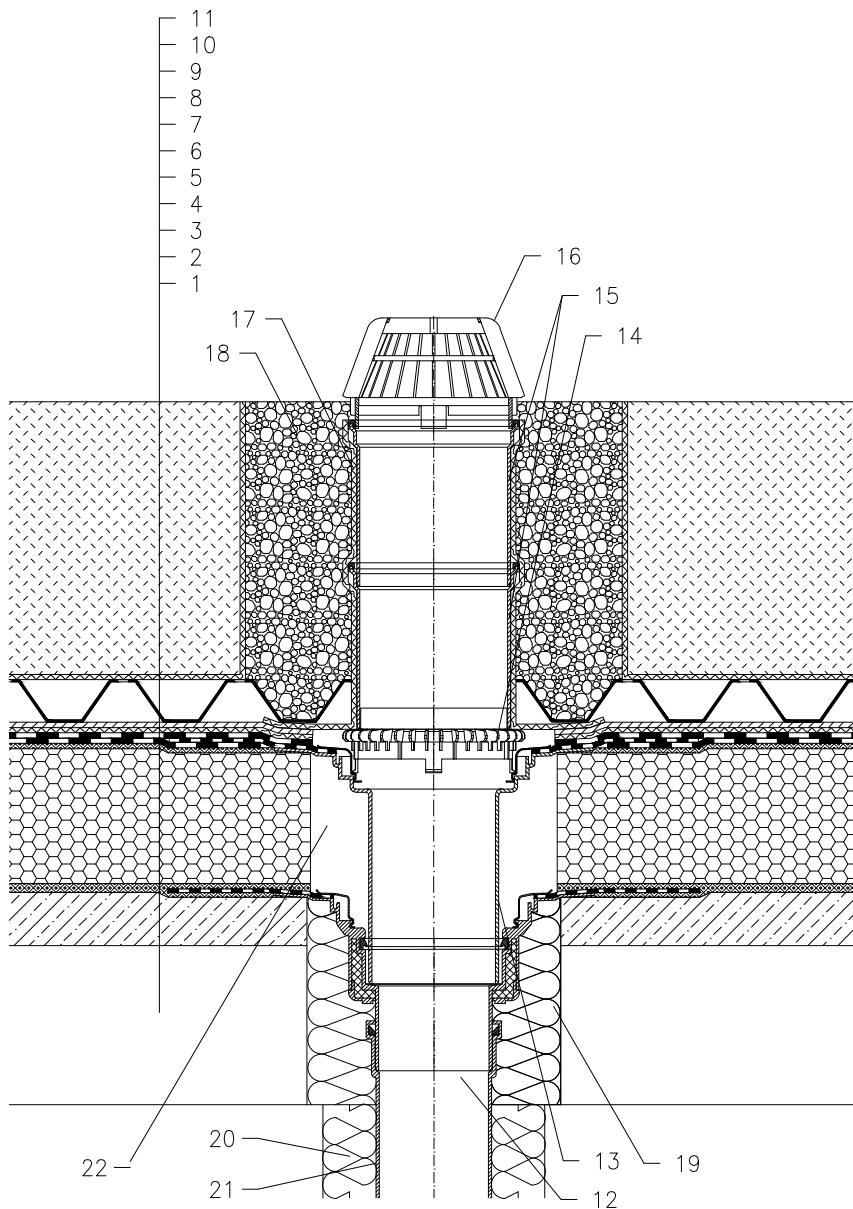

- 1 SUPPORT CONSTRUCTION
- 2 GRAVITY LAYER
- 3 HOT BITUMEN
- 4 THERMAL INSULATION – CELLULAR GLASS
- 5 HOT BITUMEN
- 6 BITUMEN SHEET WATERPROOFING WITH FLL CERTIFICATE SOLID GLUED
- 7 DILATATION LAYER
- 8 DRAINAGE LAYER
- 9 WATER ACCUMULATING LAYER
- 10 FILTER LAYER
- 11 VEGETATION LAYER (OVER 200 mm)
- 12 FLAT-ROOF DRAIN HL62H WITH INSULATED DRAIN BODY, WITH FACTORY WELDED BITUMEN MEMBRANE ϕ 500 mm, THICKNESS 4 mm
- 13 EXTENSION HL65H WITH FLANGE AND FACTORY WELDED BITUMEN MEMBRANE ϕ 500 mm, THICKNESS 4 mm
- 14 GRAVEL GUARD HL160
- 15 EXTENSION HL350
- 16 DOMED PLASTIC GRATE ϕ 180 mm (INCL. WITH HL62H)
- 17 SEPARATING LAYER
- 18 GRANULAR FILL
- 19 ASSEMBLY FOAM
- 20 DOWNPIPE THERMAL INSULATION
- 21 DOWNPIPE
- 22 FILL FREE SPACE WITH MINERAL WOOL

NOTE:

FLAT-ROOF DRAIN HL62.1H HEATED (230V, 10–30 WATTS) CAN BE USED.

ASSEMBLY INLET: ϕ 255 mm, OR 255 x 380 mm

122321B