

ROOF WITH THERMAL INSULATION – EXTENSIVE GRASSING, CLASSICAL LAYERS,
COMPACT ROOF VARIANT, BITUMEN SHEETS

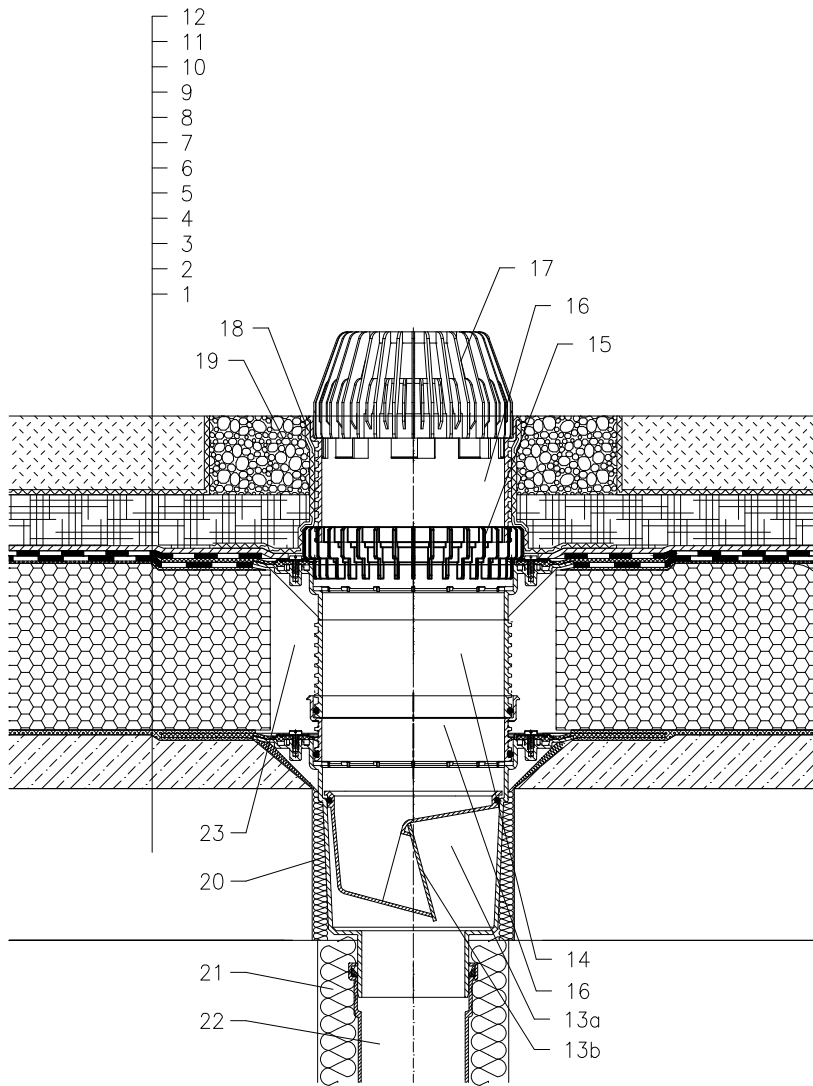

- 1 SUPPORT CONSTRUCTION
- 2 CONCRETE GRAVITY LAYER
- 3 HOT BITUMEN
- 4 THERMAL INSULATION – FOAMED GLASS
- 5 HOT BITUMEN
- 6 BITUMEN SHEET WATERPROOFING
- 7 BITUMEN SHEET WATERPROOFING
- 8 SEPARATING LAYER
- 9 DRAINAGE LAYER
- 10 WATER ACCUMULATING LAYER
- 11 FILTER LAYER
- 12 VEGETATION LAYER (UNDER 200mm)
- 13a DRAIN BODY HL616HK
WITH BITUMEN MEMBRANE \varnothing 500 mm
- 13b FROST-PROOF FLAP HL0606.3E
(NOT INCLUDED IN HL616HK)
- 14 EXTENSION HL618H WITH BITUMEN MEMBRANE
 \varnothing 500 mm; INCL. O-RING (HL620)
- 15 DRAINAGE RING HL190
- 16 EXTENSION HL620
- 17 LEAF STRAINER \varnothing 180 mm
(INCLUDED IN HL62H)
- 18 SEPARATING LAYER
- 19 GRANULAR FILL
- 20 ASSEMBLY FOAM
- 21 DOWNPIPE THERMAL INSULATION
- 22 DOWNPIPE
- 23 FILL FREE SPACE WITH MINERAL WOOL

NOTICE:

TO HEAT THE DRAIN, YOU MAY USE HEATING KIT HL609 WITH SELF-REGULATING HEAT SOURCE 36W/230V. (THE HEATING TAPE MUST BE WRAPPED AROUND THE DRAIN BODY BEFORE INSTALLATION).
RECOMMENDED BOREHOLE DIAMETER IS \varnothing 290mm, OR: \varnothing 290x290mm
DURING INSTALLATION TAKE CARE, THAT THE FLANGE POSITION IS ON THE LOWEST LEVEL OF DRAINAGE. WE RECOMMEND, TO SITE IT APPR. 1cm BELOW THE SCREED.
TO AVOID CONDENSATE WATER TAKE CARE OF THERMAL INSULATION ON THE CONSTRUCTION SITE.

122311BY