

WARM ROOF – LOADED SYSTEM, CLASSICAL STRUCTURE, WITH MOISTURE STOP,
 TRAPEZOIDAL PLATE SUPPORTING STRUCTURE, BITUMEN SHEET WATERPROOFING

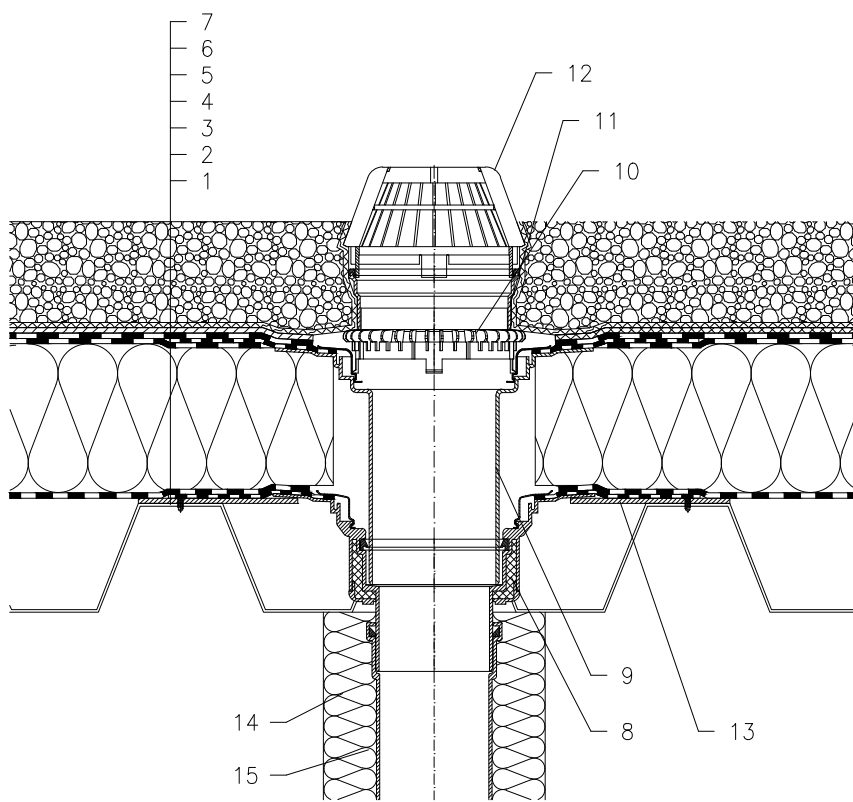

- 1 TRAPEZOIDAL PLATE
- 2 MOISTURE STOP AND TEMPORARY SAFETY WATERPROOFING FROM BITUMEN SHEET
- 3 THERMAL INSULATION
- 4 BITUMEN SHEET WATERPROOFING LAID LOOSE
- 5 DRAINAGE LAYER
- 8 FILTER LAYER
- 7 STABILIZING LAYER
- 8 FLAT-ROOF DRAIN HL62H WITH INSULATED DRAIN BODY, WITH FACTORY WELDED BITUMEN MEMBRANE \varnothing 500 mm, THICKNESS 4 mm
- 9 EXTENSION HL65H WITH FLANGE AND FACTORY WELDED BITUMEN MEMBRANE \varnothing 500 mm, THICKNESS 4 mm
- 10 GRAVEL GUARD HL160
- 11 EXTENSION HL350
- 12 DOMED PLASTIC GRATE \varnothing 180 mm (INCL. WITH HL64H)
- 13 MOUNTING METAL PLATE
- 14 DOWNPIPE THERMAL INSULATION
- 14 DOWNPIPE

NOTE:

FLAT-ROOF DRAIN HL62.1H HEATED (230V, 10-30 WATTS) CAN BE USED.

ASSEMBLY INLET: \varnothing 255 mm, OR 255 x 380 mm

121213B