

WARM ROOF – ANCHORED SYSTEM, CLASSICAL STRUCTURE, WITHOUT MOISTURE STOP,  
 TRAPEZOIDAL PLATE SUPPORTING STRUCTURE, BITUMEN SHEET WATERPROOFING

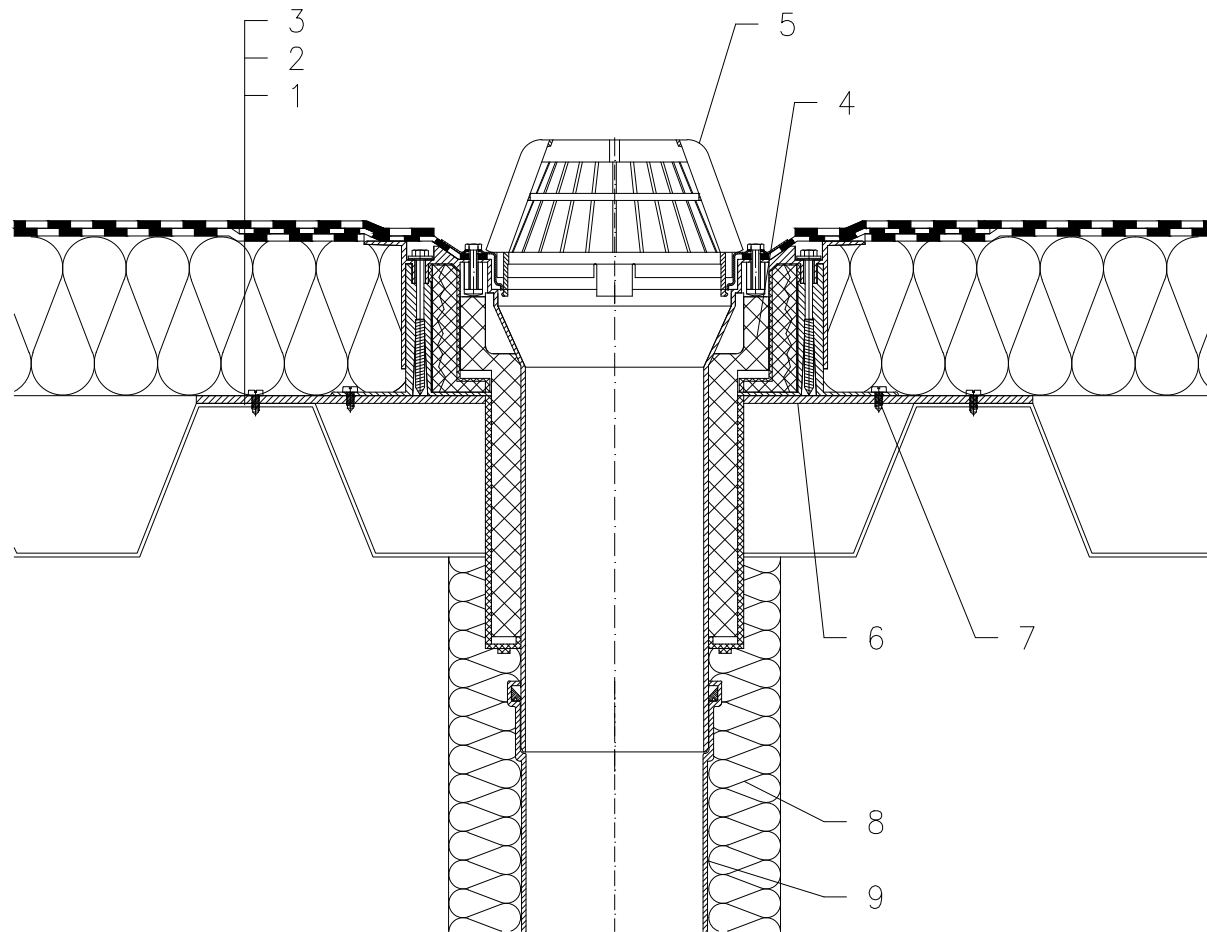

- 1 TRAPEZOIDAL PLATE
- 2 THERMAL INSULATION
- 3 BITUMEN SHEET WATERPROOFING LAID LOOSE AND MECHANICALLY ANCHORED
- 4 FLAT-ROOF DRAIN HL63H DRAINBOX, WITH INSULATED DRAIN BODY, TELESCOPED OUTER-HOUSING FOR PRECISE ADJUSTMENTS TO INSULATIONS 100-160 mm, FACTORY WELDED BITUMEN MEMBRANE  $\varnothing$ 500 mm, THICKNESS 4 mm
- 5 DOMED PLASTIC GRATE  $\varnothing$ 180 mm (INCL. WITH HL63H)
- 6 MOUNTING METAL PLATE
- 7 ANCHOR BOLT
- 8 DOWNPIPE THERMAL INSULATION
- 9 DOWNPIPE

NOTE:

FLAT-ROOF DRAIN HL63.1H HEATED (230V, 10-30 WATTS) CAN BE USED.

ASSEMBLY INLET:  $\varnothing$ 255 mm, OR 255x400 mm

121212A