

WARM ROOF – LOADED SYSTEM, CLASSICAL STRUCTURE, WITH MOISTURE STOP,
CONCRETE SUPPORTING STRUCTURE, PLASTIC FOIL WATERPROOFING

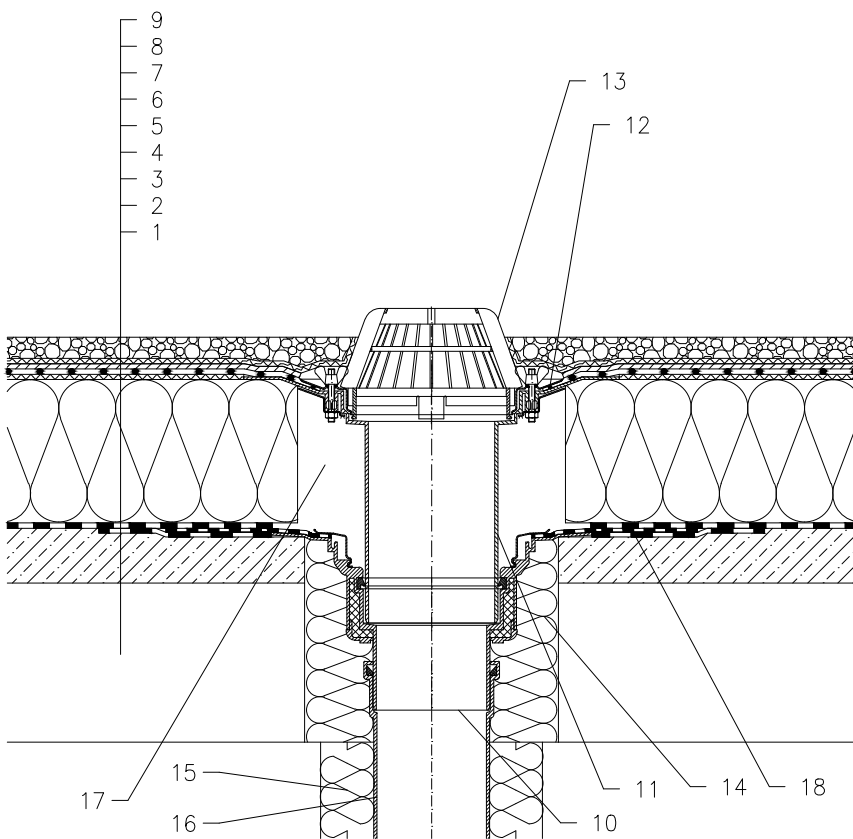

- 1 SUPPORT CONSTRUCTION
- 2 GRAVITY LAYER
- 3 DILATATION LAYER AND MOISTURE STOP FROM BITUMEN SHEET
- 4 THERMAL INSULATION
- 5 DILATATION LAYER
- 6 PLASTIC FOIL WATERPROOFING LAID LOOSE
- 7 DRAINAGE LAYER
- 8 FILTER LAYER
- 9 STABILIZING LAYER
- 10 FLAT-ROOF DRAIN HL62H WITH INSULATED DRAIN BODY,
WITH FACTORY WELDED BITUMEN MEMBRANE ϕ 500 mm,
THICKNESS 4 mm
(FOR PVC SHEETINGS FLAT -ROOF DRAIN HL62P;
FOR FPO SHEETINGS BASED ON PP FLAT -ROOF DRAIN HL62F)
- 11 EXTENSION HL65 WITH FLANGE, STAINLESS STEEL
CLAMPING RING AND LIP SEAL
(FOR PVC SHEETINGS FLAT -EXTENSION HL65P;
FOR FPO SHEETINGS BASED ON PP FLAT -EXTENSION HL65F)
- 12 SEALING PACKING (SEE DETAIL-ACCESSORIES)
- 13 DOMED PLASTIC GRATE ϕ 180 mm (INCL. WITH HL62H)
- 14 ASSEMBLY FOAM
- 15 DOWNPIPE THERMAL INSULATION
- 16 DOWNPIPE
- 17 FILL FREE SPACE WITH MINERAL WOOL
- 18 BITUMEN MEMBRANE, ϕ 750 mm

NOTE:

FLAT-ROOF DRAIN HL62.1H HEATED (230V, 10-30 WATTS) CAN BE USED.

ASSEMBLY INLET: ϕ 255 mm, OR 255x380 mm

121123A