

WARM ROOF – ANCHORED SYSTEM, CLASSICAL STRUCTURE, WITHOUT MOISTURE STOP,
CONCRETE SUPPORTING STRUCTURE, PLASTIC FOIL WATERPROOFING

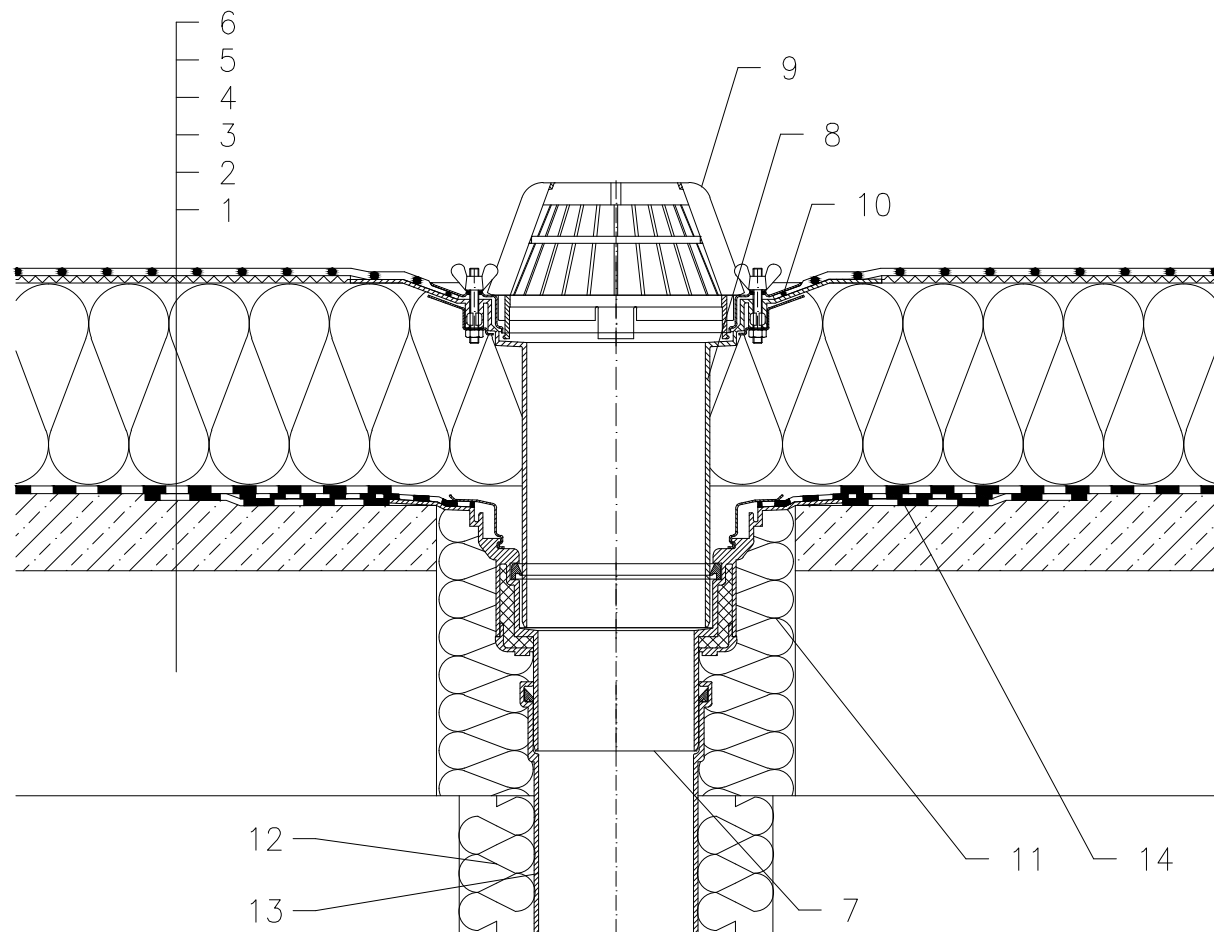

- 1 SUPPORT CONSTRUCTION
- 2 GRAVITY LAYER
- 3 DILATATION LAYER AND TEMPORARY SAFETY WATERPROOFING FROM BITUMEN SHEET
- 4 THERMAL INSULATION
- 5 DILATATION LAYER
- 6 PLASTIC FOIL WATERPROOFING LAID LOOSE AND MECHANICALLY ANCHORED
- 7 FLAT-ROOF DRAIN HL62H WITH INSULATED DRAIN BODY, WITH FACTORY WELDED BITUMEN MEMBRANE ϕ 500 mm, THICKNESS 4 mm
(FOR PVC SHEETINGS FLAT –ROOF DRAIN HL62P;
FOR FPO SHEETINGS BASED ON PP FLAT –ROOF DRAIN HL62F)
- 8 EXTENSION HL65 WITH FLANGE, STAINLESS STEEL CLAMPING RING AND LIP SEAL
(FOR PVC SHEETINGS FLAT –EXTENSION HL65P;
FOR FPO SHEETINGS BASED ON PP FLAT –EXTENSION HL65F)
- 9 DOMED PLASTIC GRATE ϕ 180 mm (INCL. WITH HL62H)
- 10 SEALING PACKING (SEE DETAIL-ACCESSORIES)
- 11 ASSEMBLY FOAM
- 12 DOWNPIPE THERMAL INSULATION
- 13 DOWNPIPE
- 14 BITUMEN MEMBRANE, ϕ 750 mm

NOTE:

FLAT-ROOF DRAIN HL62.1H HEATED (230V, 10-30 WATTS) CAN BE USED.

ASSEMBLY INLET: ϕ 255 mm, OR 255x380 mm

121122