

ROOFS WITHOUT THERMAL INSULATION – CAR PARK, PLASTIC FOIL

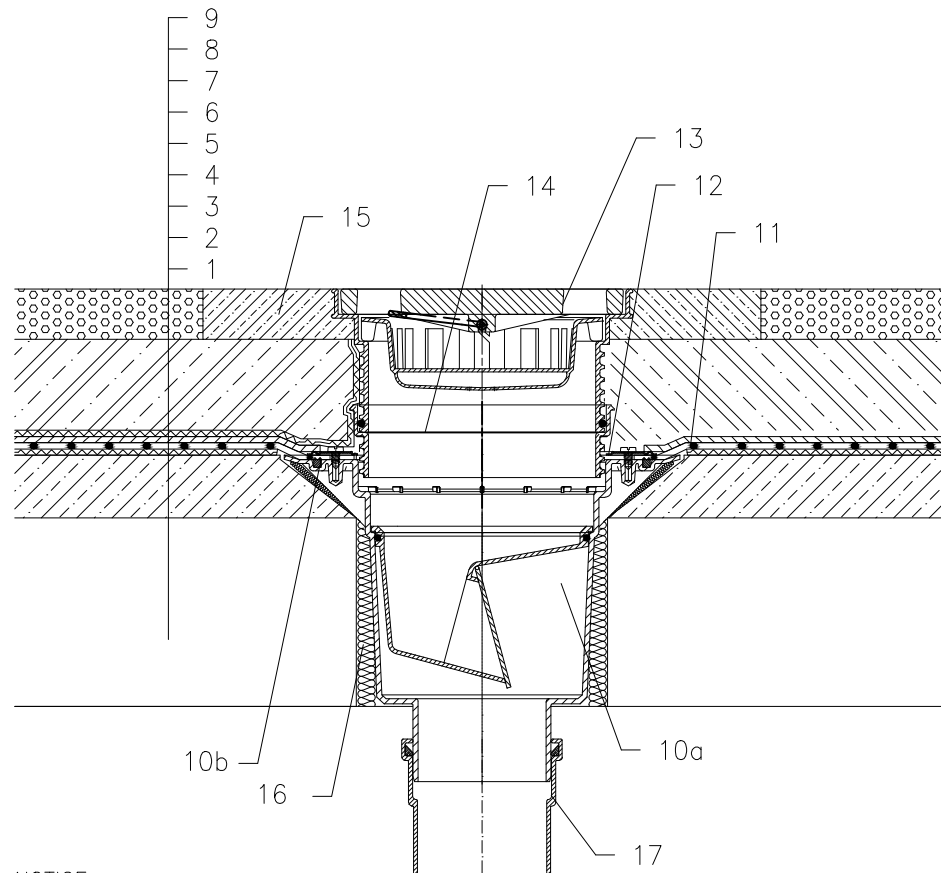

- 1 SUPPORT CONSTRUCTION
- 2 CONCRETE GRAVITY LAYER
- 3 SEPARATING AND DILATATION LAYER
- 4 PLASTIC FOIL WATERPROOFING
- 5 DILATATION LAYER
- 6 DRAINAGE LAYER
- 7 FILTER LAYER
- 8 REINFORCED CONCRETE
- 9 CAST ASPHALT
- 10a TERRACE DRAIN HL616 WITH FROST-PROOF FLAP AND FLANGE
LOAD CLASSIFICATION L15 (MAX 1500 kg)
alternative DRAIN HL616.1, LOAD CLASSIFICATION M125 (MAX 12,5 t)
- 10b SEALING KIT HL86.0 – WITHOUT SHEETING,
- 11 PRE-CUT PART FOR SEALING COLLAR, SEE TOPIC "ATTACHEMENTS"
- 12 NO TIGHT CONNECTION BECAUSE OF DISCHARGE OF LEAKAGE WATER
- 13 EXTENSION WITH CAST IRON GRATE 226x226 mm AND PLASTIC FRAME 240x240 mm (INCLUDED IN HL616)
- 14 EXTENSION HL620
- 15 CONCRETE 1000x1000x100 mm
- 16 ASSEMBLY FOAM
- 17 DOWNPIPE

NOTICE:

TO HEAT THE DRAIN, YOU MAY USE HEATING KIT HL609 WITH SELF-REGULATING HEAT SOURCE 36W/230V. (THE HEATING TAPE MUST BE WRAPPED AROUND THE DRAIN BODY BEFORE INSTALLATION).
RECOMMENDED BOREHOLE DIAMETER IS $\varnothing 290\text{mm}$, OR: $\nabla 290 \times 290\text{mm}$
DURING INSTALLATION TAKE CARE, THAT THE FLANGE POSITION IS ON THE LOWEST LEVEL OF DRAINAGE. WE RECOMMEND, TO SITE IT APPR. 1cm BELOW THE SCREED.
TO AVOID CONDENSATE WATER TAKE CARE OF THERMAL INSULATION ON THE CONSTRUCTION SITE.

112212Y